

# 3-drive PRO

# USER'S MANUAL (Product Number: 3DP)

Thank you for purchasing PIVOT product.  
Please read this manual carefully and keep it for future reference.

If this product is given to another user, make sure to include this User's Manual.

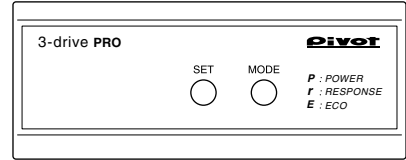
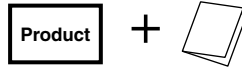

## Contents

Before Using / Contents .....	1
Part Names .....	1
Features .....	2
<b>procedure 1</b> Connecting The Wires .....	3
<b>procedure 2</b> Installing The Product .....	3
<b>procedure 3</b> Initial Settings (Degree of Acceleration Setting) .....	4
How to Operate .....	5
Display Items .....	6
Troubleshooting .....	7

## Please check the contents of the package

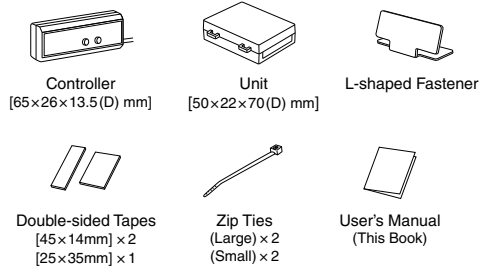

## After installation, make sure to carry out "Initial Settings".

After having installed this product, make sure to make settings for your car's special characteristics by carrying out the "Initial Settings" on Page 4. If the "Initial Settings" are not carried out, a **Check Engine Light** may go on. Also, the unit will remain in **NORMAL Mode** even if the Mode is switched.

### Worried about Installation?

If you are worried about carrying out wiring or other installation procedures please consult your dealer.

### Only use 3-drive Specialized Harness.

Using another type of harness will cause troubles and failure; use only the 3-drive specialized harness.

### Set to NORMAL Mode upon Removal of Product.

When uninstalling the product, make sure to return it to NORMAL Mode before carrying out any work. Reconnecting this product in a different mode may cause the Check Engine Light to come on.

### Modifying this Product is Forbidden.

Under no circumstances should modifications or changes be made to this product. Doing so may cause damage not only to the product, but to the car and the operation of the car in which it is installed.

## Part Names

### 1 Display

- Mode Display
- Degree of Acceleration Display (5-100%)
- Display Each Settings

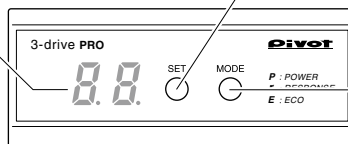

### 2 SET Switch

- For Adjusting the Change Ratio for each Mode
- Initial Settings

### 3 MODE Switch

- Switching Modes

### Turning off the Display

Note: This product is interlocked with the ECU (engine computer) power. Depending on the model of car, the display may remain on for up to 15 minutes even after the ignition has been turned off; this is normal.

# Features

## No OBD Connection Necessary! Low-Profile Controller provides Genuine-Style Installation

Compatible with Collision Mitigation System and Euro Car

### Easy Connection to Accelerator Connector

Simplified wiring prevents signal malfunctions caused by decreased voltage due to low-current circuitry.

### Use with OBD Connected Products OK

With no need for a power connection to the OBD, it is possible to use other OBD connected products without a splitter connection.

### Compact Controller Provides Genuine-Style Installation

The compact, thin, square design with accentuated edge allows for installation in any number of places without that added-on look.

### 17 Step / 4 Mode Wide-Range Adjustment

The four modes include: "POWER" mode with 7 steps for increasing response across all ranges, "RESPONSE" mode with 5 steps for increasing response, like a wire throttle, in the lower and middle ranges, "ECO" mode with 5 steps for suppressing rapid acceleration to help increase gas mileage, and "NORMAL" mode for regular driving.

### High Precision Accelerator Opening Monitor

The highly precise monitoring displays accelerator opening in units of 1% from 5 to 100%.

### Optimized Control for Smooth Ride

Throttle control at all levels has been optimized to provide a silky smooth ride.

### Also Compatible with Collision Mitigation System and Euro Car

This controller can be used in not only euro car, but also, those equipped with collision mitigation systems.

### Set to Prevent Malfunction

The initialization style set-up makes sure that malfunction will never occur no matter what type of pedal is being used.

### Safety System for Extra Peace of Mind

The safety system which automatically returns to "NORMAL" mode upon poor connection or trouble ensures your safety.

#### Comparison of Acceleration Time

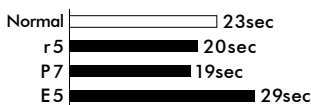

#### Comparison of Fuel Consumption

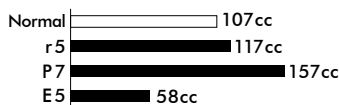

r5: MAX. RESPONSE mode P7: MAX. POWER mode E5: MAX. ECO mode

HONDA STEP WAGON (RG1) / Running distance: 0-400 m / Degree of acceleration: 30%

### Examples of Changes in Throttle Opening

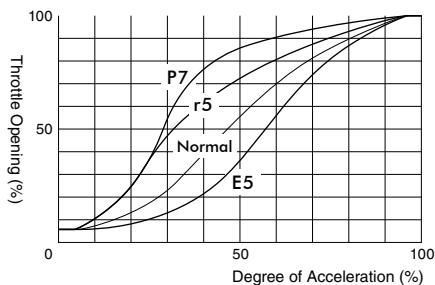

P7: MAX. POWER Mode r5: MAX. RESPONSE Mode  
E5: MAX. ECO Mode

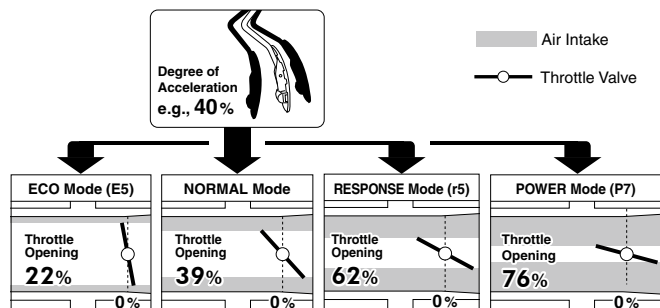

Note: In some car models with a Valvematic engine, control is carried out by the exhaust valve rather than the throttle valve.

Before Using

Features

Connecting The Wires

Installing The Product

Initial Settings

How to Operate

Trouble-Shooting

# procedure 1

## Connecting The Wires

### Basic Wiring

When installing make sure to use the correct Specialized Harness for your car model.

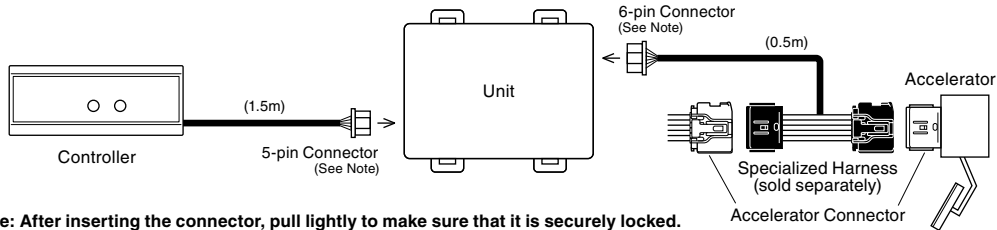

Note: After inserting the connector, pull lightly to make sure that it is securely locked.

#### Controller

**5-pin Connector** Connect to the side of the unit.

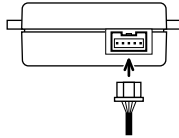

#### Specialized Harness (sold separately)

**6-pin Connector** Connect to the side of the unit.

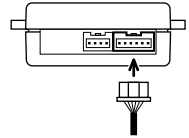

Only disconnect the accelerator connector after having waited at least 15 minutes from the time that the ignition was turned OFF.

Depending on the type of vehicle, if the connector is disconnected before the ECU power is switched OFF the Check Engine Light may go on. (If the Light comes on: > Refer to Page 8, "How to Turn Off the Check Engine Light")

Note: For details about connecting the specialized harness, please refer to the user's manual that came with that harness.

Turn the ignition to the OFF position.



Passage of over 15 minutes

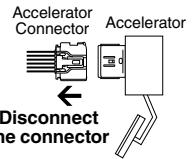

# procedure 2

## Installing The Products



Do not use magnetic holders, such as for a smartphone, to prevent malfunction.



Please be sure to bundle away all wires with tape not to get damaged by any steel plate or screws as this may cause short circuit.

**Installing The Controller** Install the Controller to a position which is easy to see.

(Example of Installation)

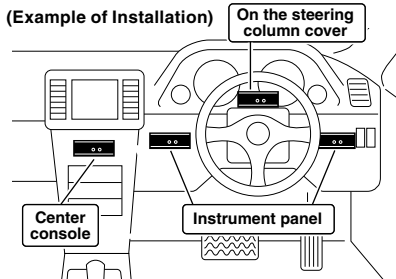

**Fastening to a Flat Place**

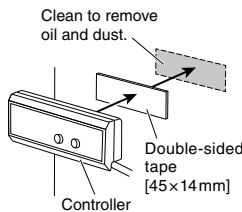

**Using the L-shaped Fastener**

By using the L-shaped Fastener that comes with this product, it is possible to install the unit on the dashboard even if it is curved or on an angle.

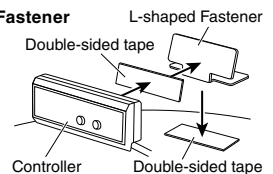

Note: It is possible to install the L-shaped Fastener in the reverse direction.

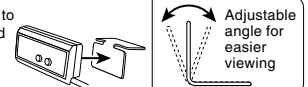

### Cable processing of the Unit

Fasten the cables not to disconnect connectors by getting caught on cables.

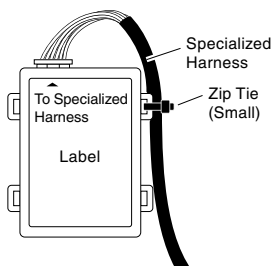

### Installing The Unit

As shown in the diagram below, fasten the unit into positions not usually affected by water.

(Example of Installation)

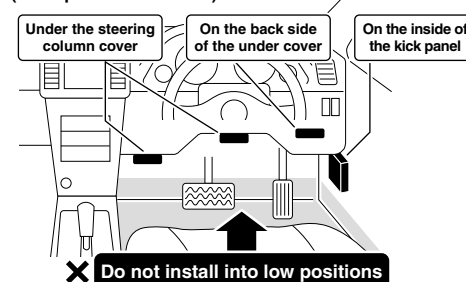

**Fastening to a Flat Place**

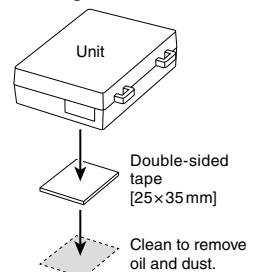

Before Using

Features

Connecting The Wires

Installing The Product

Initial Settings

How to Operate

Troubleshooting

**procedure 3**

# Initial Settings (Degree of Acceleration Setting)

Make sure to carry out these settings.

When installing for the first time



**Initial Settings**

When installing into a different car



**Initial Settings**

- This operation sets the car's accelerator characteristics into the controller unit.
- If the "Initial Settings" are not carried out, the unit will remain in NORMAL Mode even if the Mode is switched.
- If this settings have been improperly made a Check Engine Light may go on.

## Before making the "Initial Settings"

1. Make settings only after having completed all wiring (connector installation).
2. Make settings with the **ignition in the ON position(engine not running)** and the gear in **P (Parking) or N (Neutral)**.

## [Making the Settings]

Operational Procedure	Controller Display Area
<p><b>1</b> Turn the ignition ON. (engine not running)</p> <p>Without braking, press down twice</p>	<p>--</p> <p>(Normal Mode)</p> <p>If -- does not appear, press the MODE switch until -- appears.</p>
<p><b>2</b> Press the SET switch until "0" is displayed.</p> <p>Press until "0" appears</p>	<p>cR</p> <p>5 4 . . . 1 0</p> <p>Count down from 5 to 0 after the "cR" blinking.</p>

The values shown in the display will vary depending on the type of car.

<p><b>3</b> When "0" appears release the SET switch.</p> <p>Release</p>	L.
<p><b>4</b> Pedal is not pressed down. (Release the accelerator to 0%)</p> <p>0%</p>	L.
<p><b>5</b> Press the SET switch.</p> <p>Set to 0%</p> <p>Press</p>	H.
<p><b>6</b> Pedal is completely pressed down. (Press in on the accelerator to 100%)</p> <p>100%</p>	H.

Operational Procedure	Controller Display Area
<p><b>7</b> With the accelerator at 100%, press the SET switch.</p> <p>Set to 100%</p> <p>Press</p>	<p>5E</p> <p>(SET)</p> <p>00</p> <p>(100%)</p>
<p><b>8</b> Once the display changes to 00. release the accelerator.</p>	<p>00</p> <p>(100%)</p> <p>--</p> <p>(Normal Mode)</p>

## 9 Setting Completed

If the device is re-installed into a different vehicle, make sure to carry out these settings again.

After having finished settings and the battery or wires have been disconnected it is not necessary to carry out "Initial Settings".

## Check the Settings

Note: If the display is incorrect, start again from step 2 above.

Do not press in on pedal

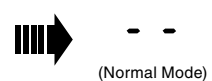
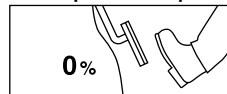

Press down on pedal

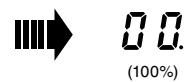
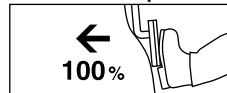

If Er is displayed at 7

If after the "Er" is shown the display returns to as shown in 4 ("L.1" or so on), it means that the degree of acceleration settings have not been confirmed properly. Re-do the settings from step 4.

Before Using

Features

Connecting The Wires

Installing The Product

Make sure to carry out this operation.

Initial Settings

How to Operate

Trouble-Shooting

# How to Operate

Before Using

## Switch the Mode

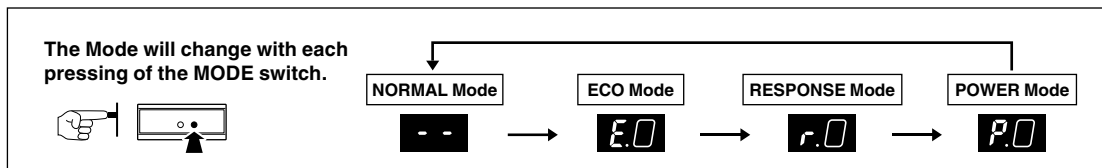

Features

## Switch the Change Ratio

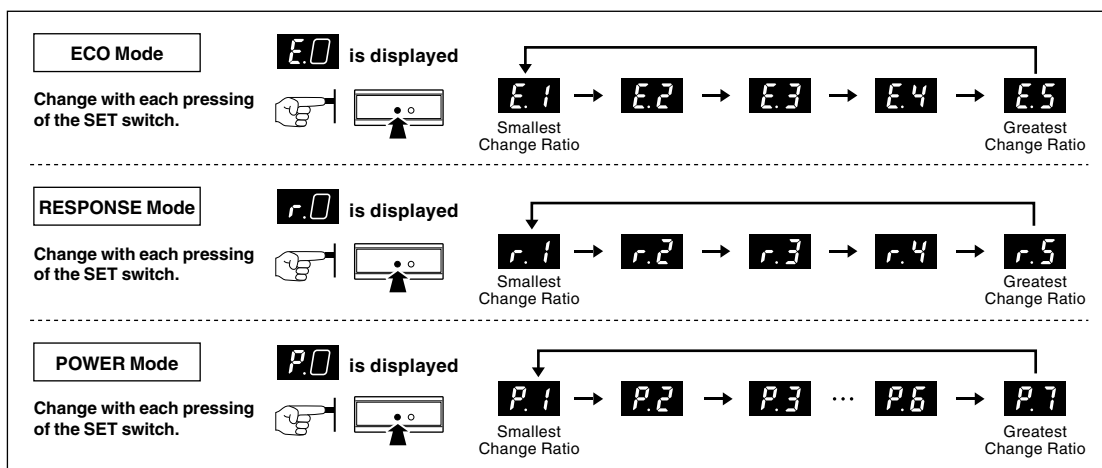

Connecting The Wires

Installing The Product

Initial Settings

How to Operate

Trouble-Shooting

## Features of each mode

**POWER Mode**

**Circuit**  
**Sports**

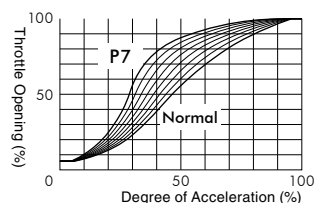
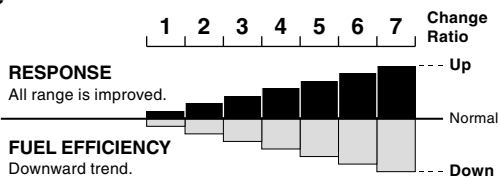

**RESPONSE Mode**

**Circuit** **Sports**

**Near the wired characteristics**

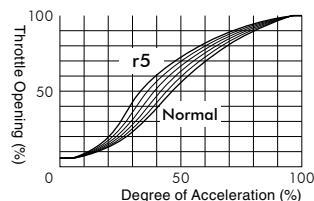

**ECO Mode**

**ECO-driving** **City driving**

**In heavy traffic** **Slippery road**

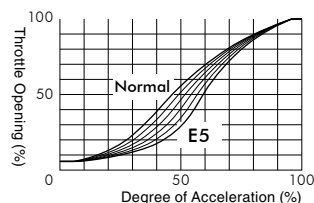
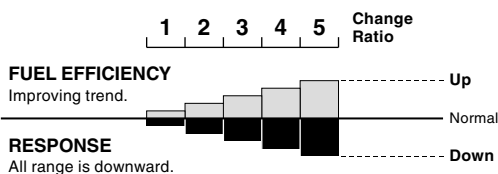

Even if the mode is switched the respective change ratio settings will not be changed.

## Degree of Acceleration Monitor

Displays the amount of pressure placed on the accelerator pedal. (output signal) [5–100%, 1% unit.]

- Degree of Acceleration Monitor shows the rate of acceleration output to the ECU where 0 represents the pedal not being pressed in and 100 equals when the pedal is fully pressed down.
- Displays accelerator opening in units of 1% from 5 to 100%. (When it is 100%, 00. is displayed.)

Degree of Acceleration (output) (20%)

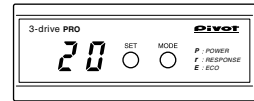

### USE 1 Check acceleration during ECO driving

To ensure reduced fuel consumption during acceleration the degree of acceleration should be between 15% and 25%. To further improve results use ECO Mode when wishing to save fuel.

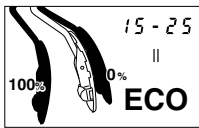

### USE 3 Check control status

With the ignition in the ON position and under NORMAL Mode press in the pedal until it reaches 40%, if the mode is changed to P7 the display should read 67 (67%) and if placed in E5 the display should change to 27 (27%).

Note: The actual display may differ slightly.

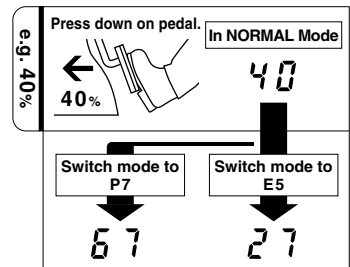

### USE 2 Check acceleration during regular driving

Please use to check the degree of acceleration for any type of driving, not just ECO Mode.

## Display Items

### Display Items



Display	Details
P. 1 ~ P. 7	POWER Mode (higher number = higher response)
r. 1 ~ r. 5	RESPONSE Mode (higher number = higher response)
E. 1 ~ E. 5	ECO Mode (higher number = lower response)
- -	NORMAL (Normal Performance)
32 (e.g. 32%)	Degree of Acceleration
00.	Degree of Acceleration (100%)

### Display for Settings

Display	Details
c A	Initial Settings Mode
L. 0	Position when accelerator is not pressed down
H. 0	Position when accelerator is fully pressed down
S E	Settings Completed

# Troubleshooting

## Concerning Basic Operations and Car Problems

Trouble	Possible Causes	Possible Solutions
The ignition is set to the ON position but the display of the Main Unit will not light up. OR the display goes OFF while in use.	Poor connection of <b>(5-pin Connector)</b> and <b>(6-pin Connector)</b> .	Please reconfirm whether wiring and connections are correct or not.
	Poor connection of <b>(Specialized Harness)</b> .	
	<b>(Specialized Harness)</b> being used is incorrect.	
A Check Engine Light has gone on. 	<b>The accelerator connector</b> or <b>(Specialized Harness)</b> was disconnected with the ignition in the ON position or within 15 minutes after having turned the ignition OFF.	Re-connect the disconnected connector and turn off the Light (See page 8 of this manual).
	The "Initial Settings" have not been properly carried out.	Make the "Initial Settings" (See page 4 of this manual) and turn off the Light (See page 8).
	The product was in a mode other than NORMAL Mode when removed from a car and installed into a different car.	After returning it to NORMAL Mode, carry out the "Initial Settings" (See page 4 of this manual) and turn off the Light (See page 8).
While making "Initial Settings" an <b>Er</b> appears in the display. 	The "Initial Settings" have not been properly carried out.	Make the "Initial Settings" (See page 4 of this manual).
The ignition has been turned OFF but the display remain on.	This product is interlocked with the ECU (engine computer) power. Depending on the model of car, the display may remain on for up to 15 minutes even after the ignition has been turned off; this is normal.	

## Concerning the Throttle Controller

Trouble	Possible Causes	Possible Solutions
Even if the Mode is changed, the changes cannot be felt. -- appears in the display. 	The "Initial Settings" have not been properly carried out.	Make the "Initial Settings" (See page 4 of this manual).
The Mode and/or the setting of change ratios can not be saved.		
	The ignition has been turned to the OFF position immediately after having finished the setting of change ratios or changing the Mode.	After having made settings of change ratios or changing the Mode, wait for at least two seconds before turning the ignition to the OFF position.

Before Using

Features

Connecting The Wires

Installing The Product

Initial Settings

How to Operate

Trouble-Shooting

## WARNING

Improper use or disregard of these warnings may result in the injury or death of people.

- When making initial settings make sure to stop the engine and place in Parking or Neutral. It is dangerous to carry out these settings while the engine is running.
- Do not work in areas where there is excessive exhaust. Due to vehicle exhaust emission poisoning or fire may result in a damage to humans.
- Do not crush the cable. Please be careful that the cable does not get crushed by the seat rail or car door steel plate, nor cut by any sharp steel plate as this may cause a poor connection or an electric short leading to fire or other danger.
- While driving DO NOT operate switches or pay prolonged attention to the display; it is extremely dangerous.
- Make sure that all wiring and fastening down of the product does not interfere with driving nor be done in such a way as to cause poor connections.

## CAUTION

Improper use or disregard of these warnings may cause injury to persons, damage the product and/or other things.

- PIVOT Corporation accepts no responsibility, in any manner whatsoever, for damage and/or trouble to your vehicle or product, nor for any accidents that are the result of the misuse of this product.
- Please confirm that the type of vehicle you wish to install into is listed in the "List of Specialized Harnesses by Car Model for 3-drive · PRO" .
- When installing this product, we recommend that if technical knowledge becomes necessary please consult a qualified mechanic.
- If the device is improperly installed or settings have been improperly made a Check Engine Light may go on.
- Please wipe with a soft dry cloth (a lens cloth).
- Please do not use alcohol or benzine. This may cause damage to the painted surface or cracks in the plastic.
- Do not, in any manner, process, take apart, or make changes to this product.

### Note

#### How to Turn Off the Check Engine Light.

If the Check Engine Light comes on due to some operational mistake, please follow the directions below to turn it off.

1. Under normal conditions, start and stop the engine several times.
2. If that does not turn off the lamp, disconnect the cable from ⊖ terminal of the battery for about 10 minutes.
3. If that does not turn off the lamp, please consult your local car dealer and have them turn it off.

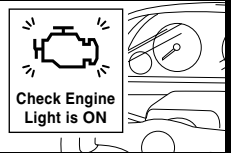

- (Note)** • Our products have already been recognized as our Industrial Property or are in the process of receiving Industrial Property status.
- We plan in the near future to take all possible legal measures to protect against unfair competition from look-alike products using similar designs, regulating characteristics, circuitry and circuitry layout.
  - We strictly prohibit the unlicensed use of the PIVOT trademark and the unauthorized use of PIVOT User's Manual.