

USER'S MANUAL

Double Gauge Set for MINI 52X-NA

Thank you for purchasing this PIVOT product.
Please read this manual carefully and keep it for future reference.

- If this product is given to another user, make sure to include this User's Manual.

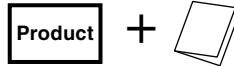

Contents

Contents / WARNING / CAUTION 1
 Features 1
 Part Names and Displays 2
 Connecting The Wires and
 Installing The Product 2~4
 Basic Operation 4
 Troubleshooting 4

Please check the contents of the package

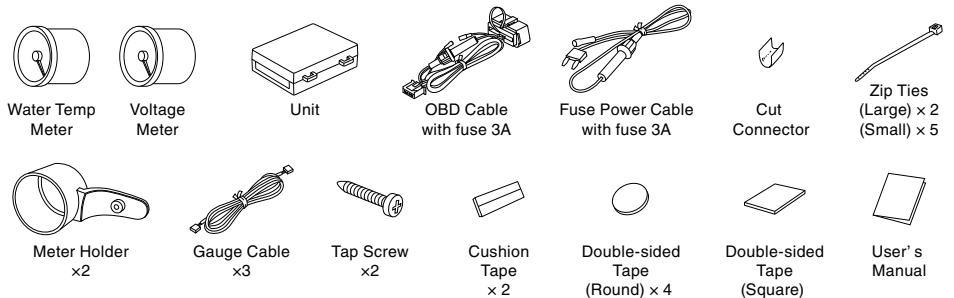

1. The display will not be proper if the ECU being used is not the standard one or if a sub-computer is being used, even in compatible car models.
2. Cannot be used in combination with other company's products that use Diagnostic Monitoring Connectors.
3. For details about using in combination with other PIVOT products that use Diagnostic Monitoring Connectors please see our Web Site at ⇒ <http://pivotjp.com/obd-e/>.
4. The meter holder can become extremely hot when exposed to direct sunlight; be particularly careful of burns.

WARNING

Improper use or disregard of these warnings may result in the injury or death of people.

- **Do not work in areas where there is excessive exhaust.**
Due to vehicle exhaust emission poisoning or fire may result in a damage to humans.
- **Do not crush the cable.**
Please be careful that the cable does not get crushed by the seat rail or car door steel plate, nor cut by any sharp steel plate as this may cause a poor connection or an electric short leading to fire or other danger.
- **Do not operate while driving.**
Operating or checking the display during driving may cause an accident; please use with the utmost consideration for safety.
- **Please securely fasten the product to a stable place and be sure to store bundle away all wires with tape, etc...**
It is very dangerous to pull tangled wires by force or allow tangled wires to interfere with driving.

CAUTION

Improper use or disregard of these warnings may cause injury to persons, damage the product and other things.

- **This product is for DC12V cars;**
Installation cannot be carried out on cars with other voltage batteries.
- **Just after installation do not exert any strong force on the product.**
When double-sided tape is used for an installation be warned that when hot the tape temporarily loses adhesiveness.
- **Do Not Use Chemical Cleansers.**
If the unit gets dirty please wipe with a soft cloth to remove any dirt. Do not use chemical cleansers such as thinner, benzene, or alcohol.
- **Do not install the product in any place subject to high temperature or any place where water may be splashed.**
- **Make sure to replace all screws and parts to their original place.**
- **Do not install the product in a place where it will cause distraction.**
- **Do not, in any manner, process, take apart, or make changes to this product.**

Features

Just by connecting to the diagnostic monitoring connector, the MINI specialized CAN communication can be analyzed and Boost and Water temperature data can be simultaneously displayed. (Not for use with incompatible models)

- Simple Connector Installation** Install by simply connecting to the diagnostic monitor connector and fuse box.
- Specialized Meter Holder** Lightweight meter holder with superior adhesion means less movement under vibration.
- LED Illumination** Uses same orange illumination as that of standard meters.

Displays and Uses

Water Temperature

- ▶ **Display** 20°C~120°C
- ▶ **Use** Prevention of overheating
Check Heating etc.

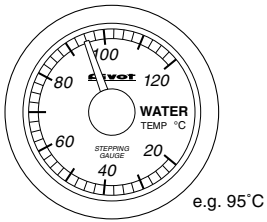

Voltage

- ▶ **Display** 7V~17V
- ▶ **Use** Check Battery.

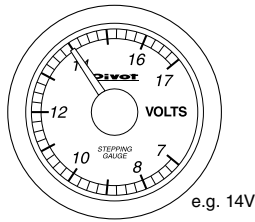

Opening Demo

The needle will move to the lowest value side several times, then it will move to the maximum value and finally to reading for current measurement item.

Part Names

[Meter]

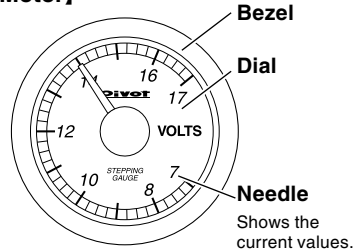

Illumination

Keep lighting the meter in operation.
(Needle: Red, Dial: Orange)

Size [Unit : mm]

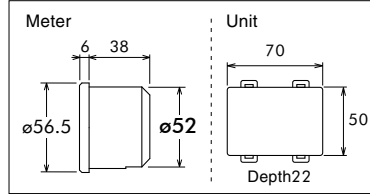

[Unit]

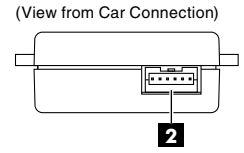
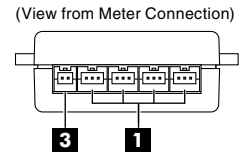

- 1 Meter connector**
Connect gauge cable
- 2 Power connector**
Connect OBD Cable
- 3 Spare**
No need to use

Connecting The Wires and Installing The Product

Basic Wiring

Please carry out wiring with the engine turned OFF and the key removed.

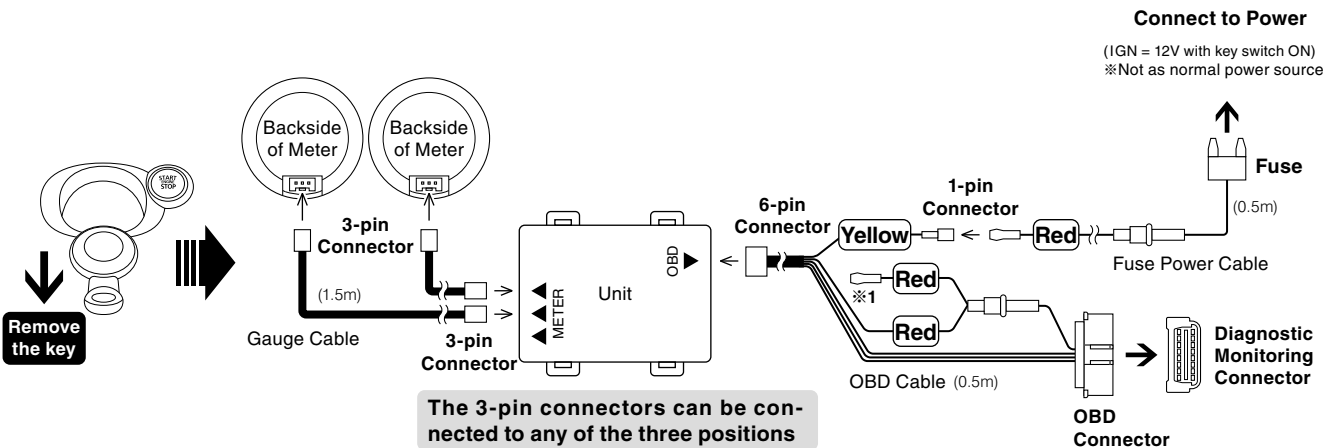

Installation Example (In case of MINI R56)

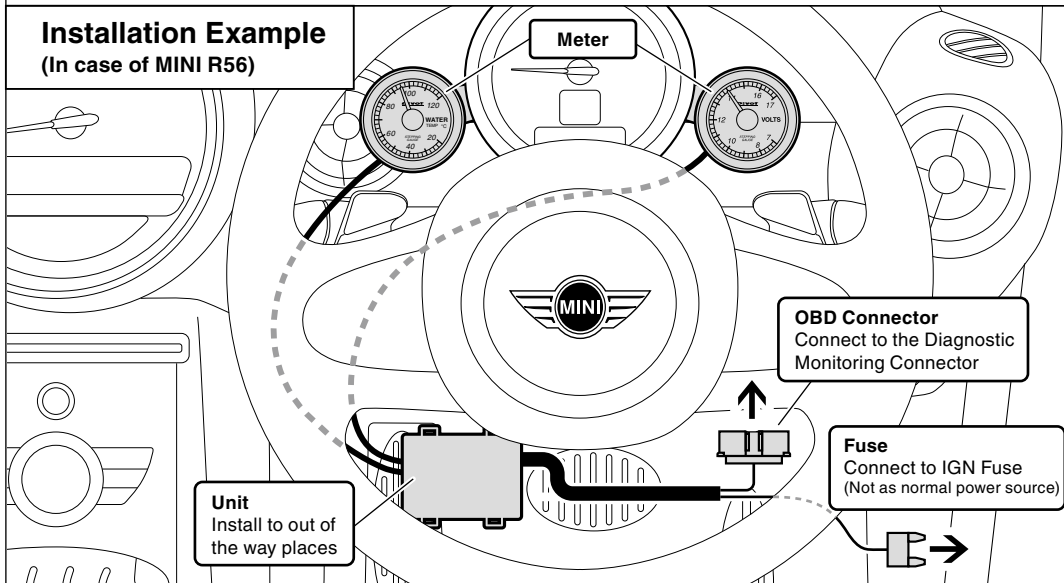

※1
Do not use Red Cable of 1-pin connector from OBD Cable fuse.

1

Connecting to a Power Source

The following is just one example of wiring to the fuse box of a BMW MINI COOPER SU16 (steering wheel on right). If your model is different and you are unsure of how to connect please contact your dealer.

1 Remove the Cover of the Fuse Box

Use a flathead screwdriver or such tool to remove the cover of the fuse box found on the side of the panel to the right of the steering wheel.

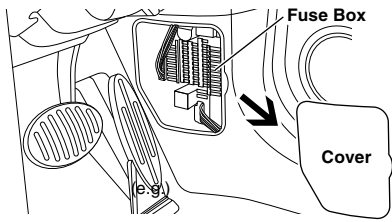

2 Insert the Fuse

Remove the fuse for IGN (12V with key switch ON), and insert the 7.5 A mini-fuse from the fuse power cable.

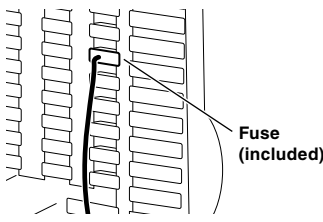

Example of a place of specific fuse

e.g. BMW MINI COOPER SU16 (steering wheel on right, 2010 MODEL)

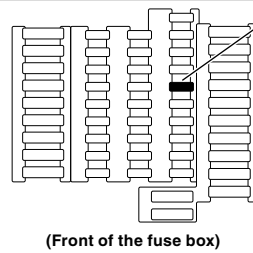

Position = 4th column from the left and 5th row from the top
Number = 32 or 34
Capacity = 7.5A

※If you wish to get power from a fuse other than the 7.5A mini-fuse, please purchase separately.

(Front of the fuse box)



If you are unable to get power from the fuse box, please wire directly to IGN (12V with key in ON position).

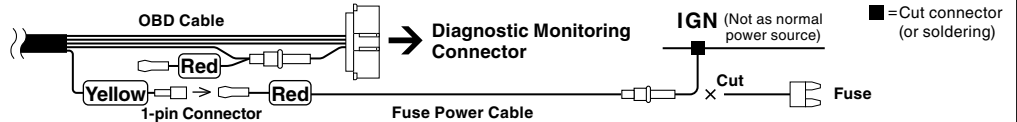

2

Connecting The OBD Connector

1 Locate the Diagnostic Monitoring Connector Position

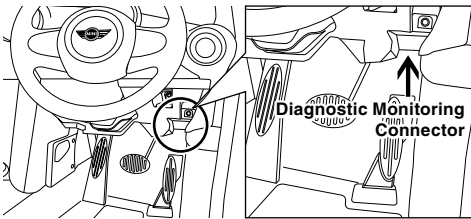

2 Open the Cover

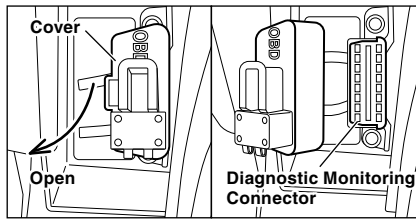

3 Completely insert the OBD Connector

Insert the OBD connector to the diagnostic monitoring connector from the Unit.

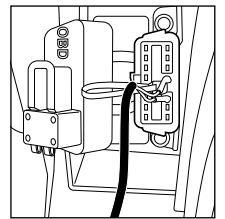

3

Fastening The Meter

Affix the supplied meter holder to the back of the standard tachometer.

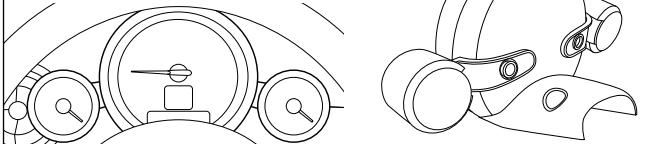

1 Remove the standard tachometer

Unscrew the two screws (torque screw T30 x 2) from the base at the back of the tachometer and remove it by pulling it forward. (As the wiring for the tachometer is connected to inside the steering column it cannot be removed. Carry out all operations with the wiring pulled out but connected.)

※Make sure not to lose any removed parts.

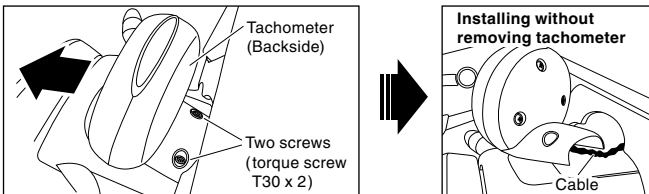

2 Unscrew the screws at the back of the tachometer

Remove the screw from the hole at the back of the tachometer.

※Put the bolt store in a safe place.

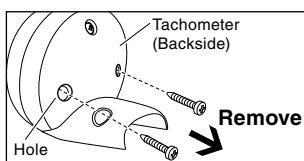

3 Affix Double-sided Tape to the Stay on the Meter Holder

Affix the provided double-sided tape (round) to the two places as shown in the figure to the right.

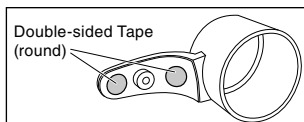

4 Lightly Fasten the Meter Holder

Line up the screw holes on the original tachometer with the screw holes on the meter holder and lightly fasten with the double-sided tape.

※Do not press too strongly on the tape; it may become difficult to remove.

When installing, please make adjustments to line up the meters on each side.

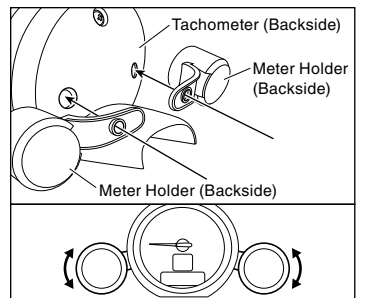

5 Fix the meter holder with the screws

Use the provided tap screws to fasten.

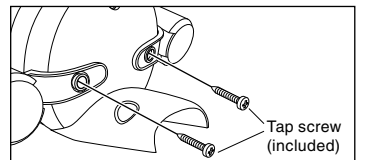

6 Return the tachometer to its original position

Return the tachometer to its original place by going in the reverse order from ① above, and securely fasten with the two screws.

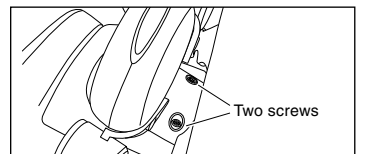

7 Fasten the meter to the meter holder

Affix the provided cushion tape to two places on the sides of the meter. Pull the meter cable through the hole at the back of the meter holder and insert it into the 5-pin connector at the back of the meter. After having decided the angle press the meter into the holder at finish the installation.

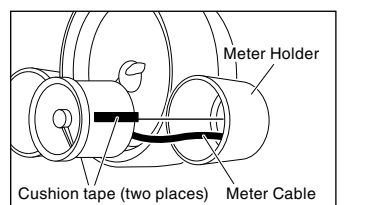

4 Connecting each Cable and the Unit and Installing

Connect Gauge Cable and OBD Cable to the Unit

● Gauge Cable

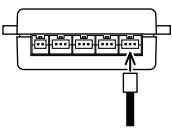

Connect to the Unit.

※ The 3-pin connectors can be connected to any of the three positions

● Fuse Power Cable



Connect to 1-pin connector of OBD Cable.

● OBD Cable

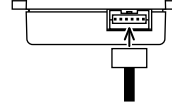

Connect to the Unit.

Installing the Unit

Fasten the unit into positions not usually affected by water.

Fastening to Flat Space

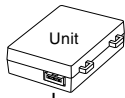

Double-sided tape(Square)

Clean to remove oil and dust.

When Fastenings to a Cable or Pipe

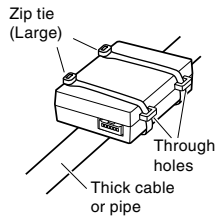

Zip tie (Large)

Through holes
Thick cable or pipe

Notes about using the OBD Connector

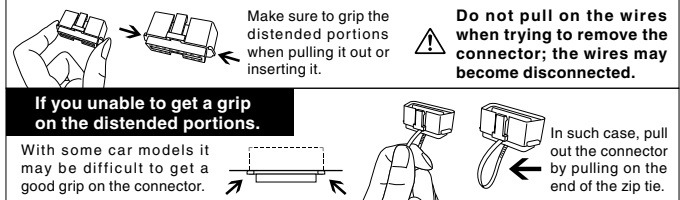

How to use the Cut Connectors

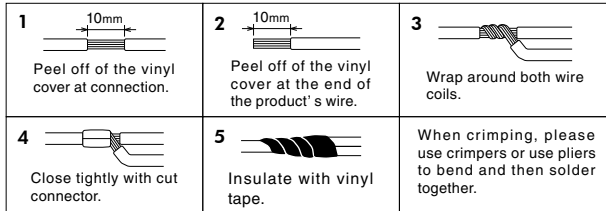

Basic Operation

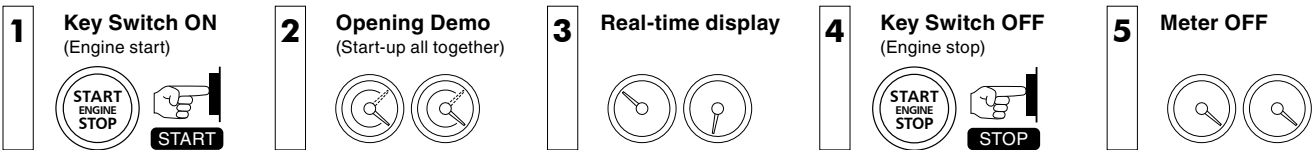

Troubleshooting

Trouble	Possible Causes	Possible Solutions
Meters do not work.	Poor connection of Gauge Cable , OBD Connector and Fuse Power Cable .	Please reconfirm whether wiring and connections of Gauge Cable , OBD Connector and Fuse Power Cable are correct or not.
	Poor connection or wrong wiring of Red cable if wired directly to the power supply.	Please reconfirm whether wiring and connections of Red cable is correct or not.
	The unit has been installed into an incompatible car model.	Please check the "Fitting List".

※Our products have already been recognized as our Industrial Property or are in the process of receiving Industrial Property status.

※We plan in the near future to take all possible legal measures to protect against unfair competition from look-alike products using similar designs, regulating characteristics, circuitry and circuitry layout.

※We strictly prohibit the unlicensed use of the PIVOT trademark and the unauthorized use of PIVOT User's Manual.