

Pivot



CYBER GAUGE
OBD or SENSOR SYSTEM



CYBER GAUGE

OBD or SENSOR SYSTEM

The Future of Cyber Gauges is Here and Now.



A Must-Have for Turbo Cars

From checking boost to estimating gas usage (vacuum side) make this a vital item for your turbo engine car.

BOOST



For Preventing Overheating and Checking Warm-up

This gauge allows you to not only check warm-up operation but help prevent overheating due to lack of coolant or trouble in the coolant line.

WATER TEMP



Battery Checking for New-Era Systems

Use to calculate battery life by checking voltage drop during idling and minimum voltage at start up, as well as, check on your battery recharging status from regenerative braking.

VOLTAGE



For Preventing Engine Trouble

Use not only to check oil cooler performance, but also, prevent engine trouble caused by viscosity reduction due to high oil temperatures.

OIL TEMP



From Sports to Eco Driving

A basic tachometer designed for checking shifting performance in both AT and MT cars, as well as, help optimize your eco-driving.

TACHOMETER



For Preventing Trouble from Oil Pressure Loss

Use to check for sudden temporary loss of oil pressure caused by higher rpm in sports driving or tilt in oil level.

OIL PRESSURE



1. Easy-to-Install OBD Connection Models

Simple Coupler Connection to Diagnostic Monitor Connector.

*Please check compatible car models with the Fitting List.

2. Sensor Connection Models

Wide Range Compatible Sensor Connection Models.
*Sensors included.

3. Low Position Holder

New meter holder allows for installation at 5 mm lower than normal.

4. Illumination

White LED lighting of Dial and Needle.



5. Peak reading and Warning

Blinks red LED at the set rpm and the Peak reading.

6. Stepping Drive

Our stepping motor is able to provide a smooth, highly precise display.



7. Linkage Possible

For a sleek one-line connection from multiple gauges to unit use our link cable (sold separately).

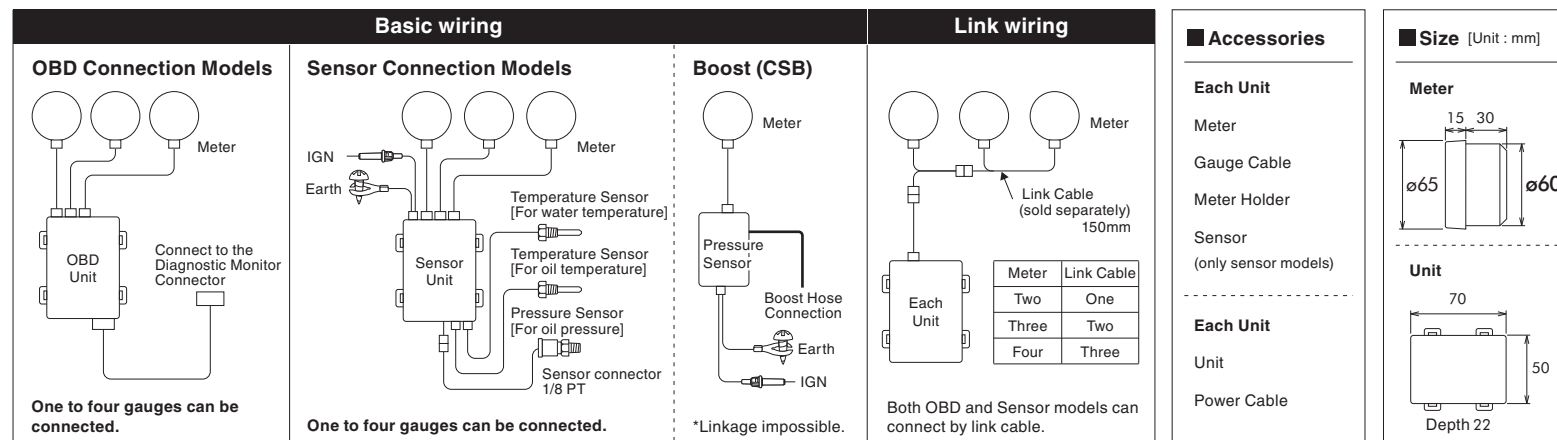

OBD Connection Models

Product	Product Number	Price
BOOST	COB	¥15,000
WATER TEMP	COW	
VOLTAGE	COV	
TACHOMETER	COT	
OBD UNIT	COU	¥8,000
LINK CABLE	CLC	¥1,500

Sensor Connection Models

Product	Product Number	Price
BOOST	CSB	¥20,000
WATER TEMP	CSW	¥16,000
VOLTAGE	COV	¥15,000
OIL TEMP	CSO	¥16,000
OIL PRESSURE	CSP	¥30,000
SENSOR UNIT	CSU	¥8,000
LINK CABLE	CLC	¥1,500

*Need to purchase each unit to operate gauges. (except CSB)