

RAIZIN Spark Type V VS-V



Thank you for purchasing our PIVOT product. Please read these instructions carefully before installing or using this device.

- When installing this product, we recommend that if technical knowledge becomes necessary please consult a qualified mechanic.
- Please do not lose this user's guide, as you will held liable for the cost of reissuing it.

CONTENTS

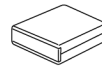

RAIZIN Unit

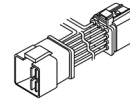

Specialized Coupler



Hex Nut x2



Double-Sided Tape x3



User's Guide

Compatibility List

IMPREZA	H14.11~	GDA/GDB/GGA	EJ20 TURBO
	H12.10~	GDB/GGB	
	H12.8~	GDA/GGA	
	H10.9~	GC8/GF8 (F type)	

FORESTER	H14.2~	SG5	EJ20 TURBO
	H12.1~	SF5 (C,D type)	

LEGACY	H10.12~	BE5	EJ20 TURBO
	H10.6~	BH5	



1. Please install safely and surely by following these instructions.
2. Please be sure to remove the ⊖ battery cable from the terminal before wiring.
3. A mistake in wiring may cause a short circuit and subsequent malfunction to the product or your car.



1. There are some model cars for which this product cannot be connected, has not been checked for wiring compatibility or for which due to the car's wiring there was a lack of results.
2. Please do not attempt to connect a similar product in the same way as our product, or install this product to a car for which the product is not compatible. Doing so may cause damage to your car's parts.

EFFECTS

VS-V due to its car model specialized ignition coil offers you the optimum improvement in performance.

- Torque and Response and Power
- Improved Fuel Efficiency and Engine Kick Over
- Stabilized Idling
- The hushed sound of an engine

FEATURES

Stabilized power at the source + Prevention of power loss due to wiring + Strengthened earth !

These bring you improved performance through the ideal ignition. Various types of load resistance and interference at the terminals, fuses, and wires in the electric circuitry on the way to the ignition coil caused ignition loss due to low voltage and pulse noise making performance nowhere near optimum. To help solve this, the Raizin Spark TypeV takes a new approach that helps to bring out 100% of your ignition's performance by stabilizing the ignition coil power at the source, making it possible to wire directly to the battery at the shortest distance, and strengthen the earth to completely prevent power loss due to wiring. It is the epoch-making device that not only stabilizes voltage to bring out the ideal ignition coil firing capabilities but also prevents power loss due wiring.

Coupler Connection for Easy-installation.

All you have to do is wire to the specified engine room coupler and connect to the battery terminals.

Uses High Frequency Wave Responsivity Circuitry and Dual Power Relays.

The optimum in performance is brought about by our superior circuitry for high frequency wave responsivity and our dual power relay system.

One-touch Removable Fuse.

Even in a case where a fuse burns out, our one-touch removable fuse makes sure there is no fuss or trouble.

The excited ionization is improved to bring you the ideal combustion.

In order to enable ideal combustion for high power it is not only necessary that the spark be strong for the initial firing, the ignition and for the combustion stroke but also it is necessary to improve the excited ionization in order that the spark is uniformly ignited within the air-fuel mixture and does not disintegrate like a sparkler. Raizin Spark by connecting closer to the ignition coil power supply (preliminary side) with its specialized high frequency wave responsivity circuitry, controls the loss of voltage and the occurrence of pulse noise from the breaking of electrical current. As a result, the break in electrical current is faster, at firing (secondary side) the speed of the spark current rises, the high frequency electromagnetic waves are strengthened, and the excited ionization is improved to bring you the ideal combustion.

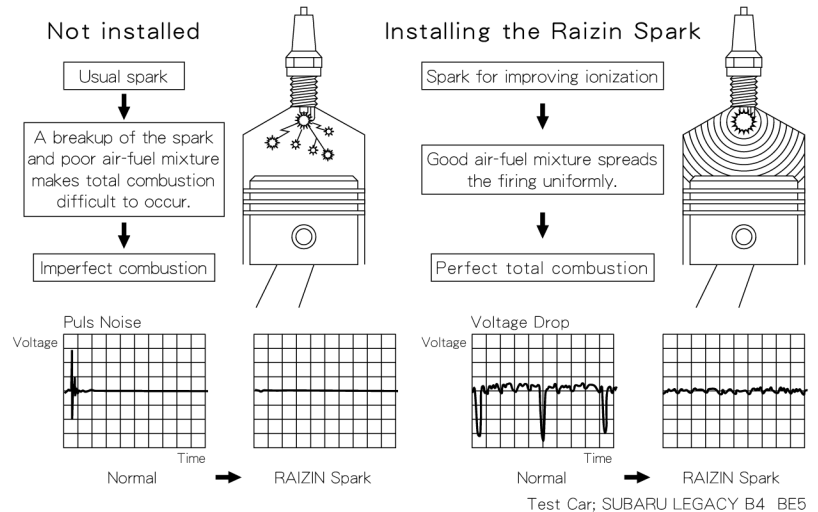

Test Car: SUBARU LEGACY B4 BE5

BASIC WIRING and PRINCIPLE

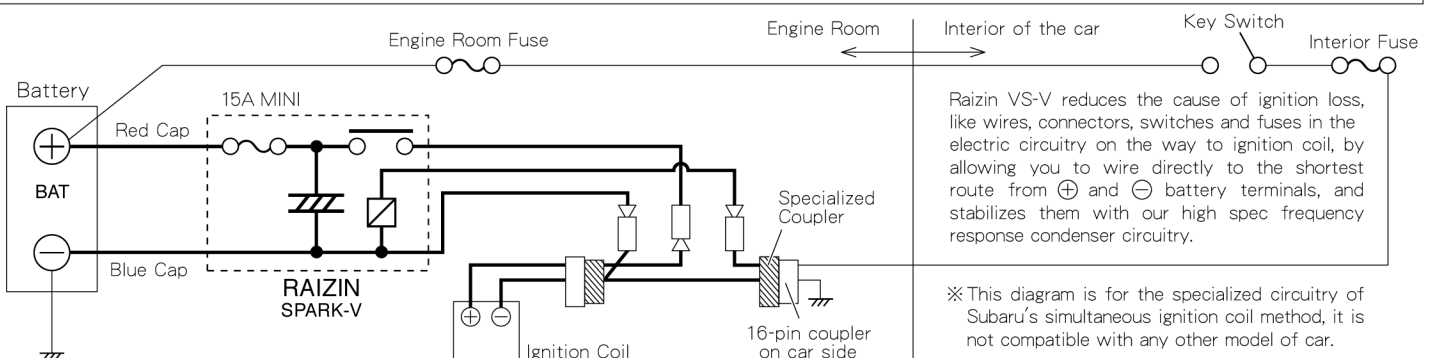

INSTALLATION

This diagram may differ from actuality depending on the car model and make.

⚠ WARNING

For safety purposes, when working on your car always disconnect the ⊖ battery terminal.

⚠ CAUTION

To prevent short circuits, after wiring, please insulate any extra wire and couplers with insulation tape.

Installation Preparation

- Remove the ⊖ cable from the ⊖ battery terminal.
- Insulate the ⊖ battery terminal with vinyl tape.

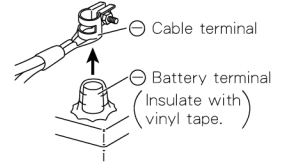

- Remove the washer tank screws at the backside of the battery.

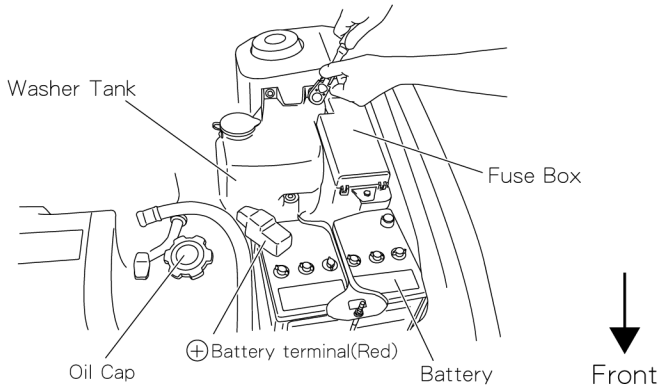

- Pull apart the 16-pin coupler from the back of a battery.

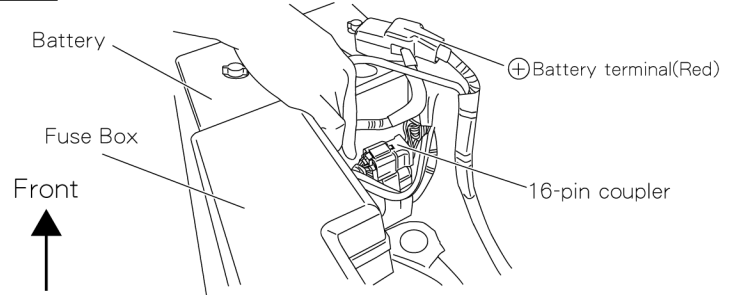

- Connect the specialized coupler to the 16-pin coupler you pulled apart, and connect the wires coming from it to the wires of matching color from the unit.

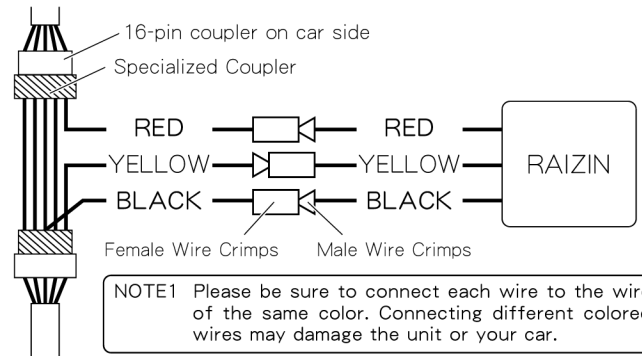

NOTE1 Please be sure to connect each wire to the wire of the same color. Connecting different colored wires may damage the unit or your car.

NOTE2 Make each connection is inserted completely, and to prevent them from pulling apart, roll each up with insulation tape.

- Remove the couplers.

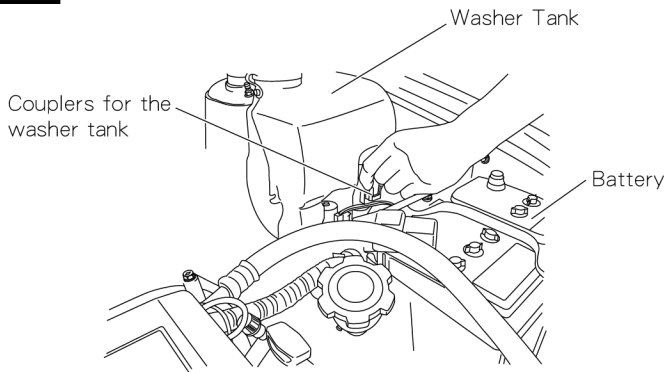

- Pull out the washer tank and put it to the side.

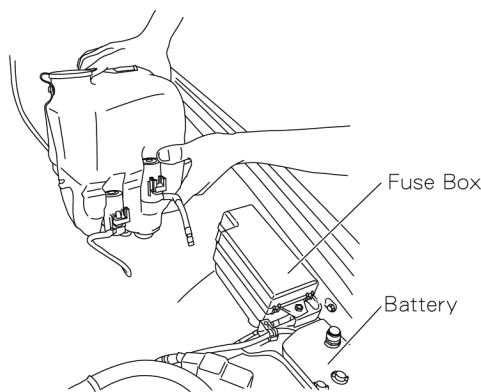

- Connect the two blue wires coming from the unit to the ⊕ and ⊖ terminals, and fasten the unit with double-sided tape to the battery or other such area.

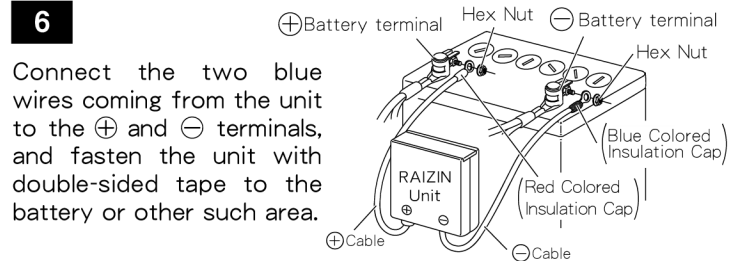

- Put all parts back in the reverse order.

CHECK OPERATION

If the device's LED comes on when the key is switched to ON, it is working properly.

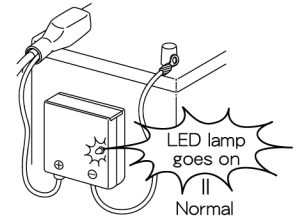

INSTALLING THE RAIZIN UNIT

※Do not to install in areas subject to water.

Circuitry has waterproof coating. But do not to install in areas subject to water or spray with water.

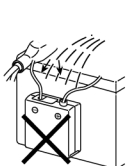

● If you install with the cables going out the top, water may enter the unit and cause damage. Make sure to install with cables going out the bottom of the unit.

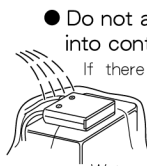

● Do not allow water to come into contact with the unit. If there is a chance of water coming into contact, please cover with waterproof sheeting. Waterproof Sheeting, etc.

⚠ CAUTION

- If you're installing on the side surface, the double-sided tape will take about two hours to become secure. During that time do not allow any vibration to the unit.
- Reinstalling will cause the tape's adhesive strength to weaken, so please do not to it.

- Clean off all oil and dirt from the bottom of the main unit and affix the double-sided tape included in the kit.
- Clean off all oil and dirt from the installation place and fasten the main unit.

