

USER'S GUIDE

X2M-C

MULTI GAUGE ø60

EURO SPEC

Thank you for purchasing PIVOT "X2M-C".

Please read these instructions carefully before installing or using this device.

Please do not lose this user's guide, as you will held liable for the cost of reissuing it.

<p>CAUTION Improper use or disregard of these warnings may result in the injury or death of people.</p> <p>Do not work in areas where there is excessive exhaust Due to vehicle exhaust emission poisoning or fire may result in a damage to humans.</p> <p>Please securely fasten the product to a stable place It is very dangerous if, while in use, the product falls off and interferes with braking.</p> <p>Do not crush the cable Please be careful that the cable does not get crushed by the seat rail or car door steel plate, nor cut by any sharp steel plate as this may cause a poor connection or an electric short leading to fire or other danger.</p> <p>Do not operate while driving Operating or checking the display during driving may cause an accident; please use with the utmost consideration for safety.</p> <p>Please be sure to store bundle away all wires with tape, etc... It is very dangerous to pull tangled wires by force or allow tangled wires to interfere with driving.</p>	<p>NOTE Improper use or disregard of these warnings may cause injury to persons, damage the product and other things.</p> <p>This product is for DC12V cars; Installation cannot be carried out on cars with other voltage batteries.</p> <p>Do Not Use Chemical Cleansers If the unit gets dirty do not use chemical cleansers such as thinner, benzene, or alcohol; please wipe with a soft cloth to remove any dirt.</p> <p>Do not install the product in any place subject to high temperature or any place where water may be splashed</p> <p>Make sure to replace all screws and parts to their original place</p> <p>Do not install the product in a place where it will cause distraction</p> <p>Do not, in any manner, process, take apart, or make changes to this product</p>
---	---

1. The display will not be proper if the ECU being used is not the standard one or if a sub-computer is being used, even in compatible car models.

2. Cannot be used in combination with products that use another company's diagnostic monitoring connectors.

3. For details about using in combination with other PIVOT products please see our Web Site at http://pivotjp.com/information/obd_conjunction-e.html.

Compatible Car Models

Cars that are after model changes are not compatible.

Vehicle	Type	Model Year	Car Model	Engine
COOPER S	R56	2007.2~	MF16S	N14B16A
COOPER S CLUBMAN	R55	2007.10 ~	MM16	

Check the contents

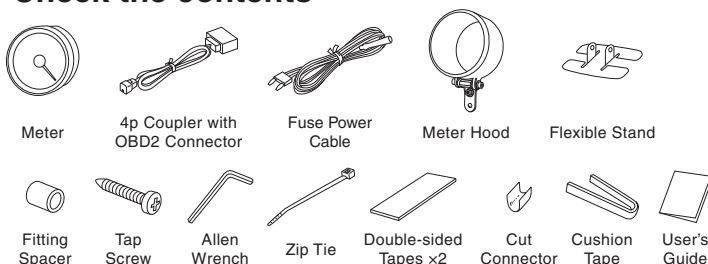

FEATURES

With our X2M-C multi-gauge, just by connecting to the diagnostic monitoring connector, the MINI specialized CAN communication can be analyzed and three types of data can be displayed. (Not for use with incompatible models)

2 types of display	With just one unit switch between two displays: Boost and Water Temperature
Smooth Action	New Controller provides needle action quick and smooth
Illumination	Same Standard Orange Illumination
Peak Hold	Display peak reading
Easy-installation	It is possible to connect directly using the coupler to the diagnostic monitoring connector meaning there is no need for troublesome wiring
Stepping Drive	Stepping motor drive brings you a high-performance display with no hunching or overshooting

Displays and Uses

1. Boost (Absolute pressure display※)

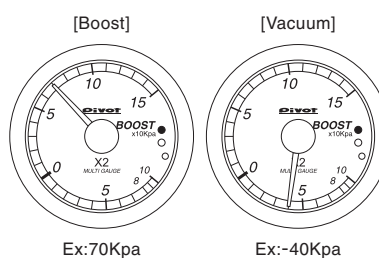

► **Display** -100~150Kpa
 ► **Use** ● Check Boost
 ● For Eco-driving [Vacuum]
 ※ This display of absolute pressure includes barometric pressure and may differ from a gauge showing relative pressure (mechanical type).
 ※ With the key in the ON position, due to altitude the boost needle may show a minus reading.

2. Water Temp

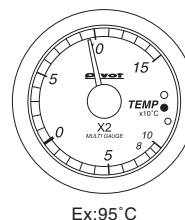

► **Display** -40°C~150°C
 ► **Use** ● Prevention of overheating
 ● Check Heating etc.

3. Peak Hold

Display peak value after the key switch ON.

► **Use** Check the peak readings

Opening Demo

Turning the key ON (engine start) will display the opening demo one time.

Illumination (Dial lighting)

The illumination is always on while driving, but because it is a low energy LED this has no effect on the vehicle performance or battery life.

WIRING METHOD

Please carry out wiring with the engine turned OFF and the key removed.

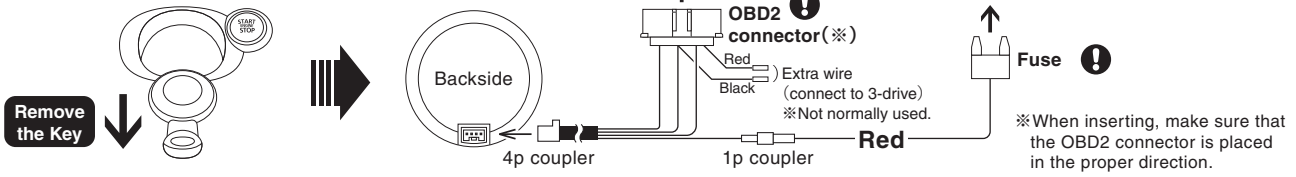

1 Connecting to a Power Source

The following is just one example of wiring to the fuse box of a BMW MINI COOPER S MF16S (steering wheel on right). If your model is different and you are unsure of how to connect please contact your dealer.

1 Remove the cover of the fuse box

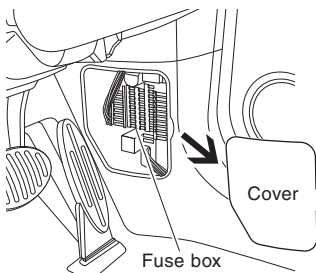

Use a flathead screwdriver or such tool to remove the cover of the fuse box found on the side of the panel to the right of the steering wheel.

2 Insert the fuse

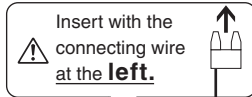

Remove the fuse for IGN, and insert the 7.5A flat mini-fuse that is connected to the OBD2 connector.

*If you wish to get power from a fuse other than the 7.5A flat mini-fuse, please purchase separately.

Ex: BMW MINI COOPER S MF16S (steering wheel on right · 2008 MODEL)

(Front of the fuse box)



Position = 4th column from the left and 5th row from the top
Number = 32 Capacity = 7.5A

at times like this If you are not using the Fuse Box

If you are unable to get power from the fuse box, please wire directly to IGN (12V with key in ON position).

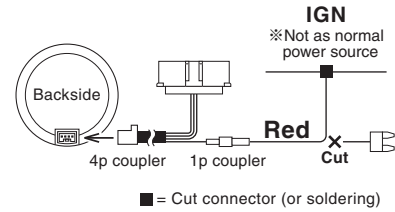

2 Connecting the OBD2 Connector

1 Locate the diagnostic monitoring connector position

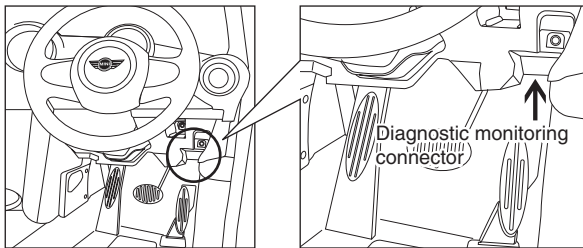

2 Open the cover

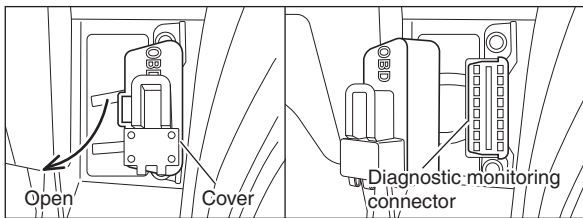

3 Completely insert the OBD2 connector

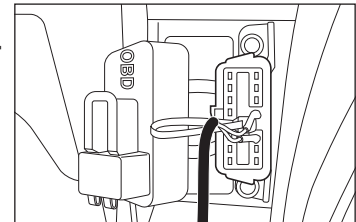

[REFERENCE 1] Notes about using the OBD2 connector

NOTE

Do not pull on the wires when trying to remove the connector; the wires may become disconnected.

Make sure to grip the distended portions when pulling it out or inserting it.

If you unable to get a grip on the distended portions

With some car models it may be difficult to get a good grip on the connector.

In such cases, use a lock tie to push or pull the connector.

at times like this When use in conjunction with the PIVOT's 3-drive

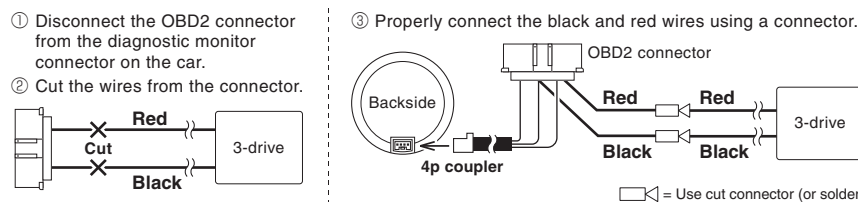

[REFERENCE 2] How to use the male wire crimps

1 Peel off about 10mm of vinyl covering from the tip of the wire.	2 Bend the outside wires around the core to make the wire thicker.	3 Pull the wire through the cover.
4 Place the wire onto the crimp.	5 Crush the center tabs of the crimp down to hold the center of the wire.	6 Crush down the outer tab of the crimp over the vinyl covering.

Note: Securely connect the male and female crimps, making sure to twist the male cover firmly into the female cover.

at times like this When use in conjunction with the PIVOT's PROGAUGE or REVLAMP

2 Please use the OBD2 wiring kit (sold separately), or be wired PROGAUGE (REV LAMP) directly.

METER INSTALLATION

We suggest installing our meter to the right side of the standard tachometer using the provided meter hood. However it can be placed anywhere you desire and may be used in conjunction with meter hoods and installed as a regular type meter.

Installation A Installing to the right side of the tachometer

Affix the supplied meter hood to the back of the standard tachometer.

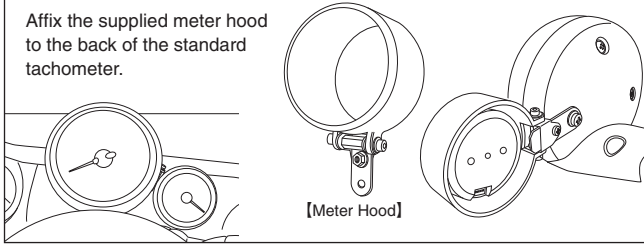

[Meter Hood]

1 Remove the standard tachometer

Unscrew the two screws (torque screw T30 x 2) from the base at the back of the tachometer and remove it by pulling it forward. (As the wiring for the tachometer is connected to inside the steering column it cannot be removed. Carry out all operations with the wiring pulled out but connected.)

※Make sure not to lose any removed parts.

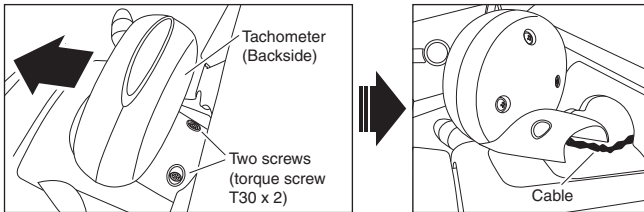

2 Unscrew the screws at the back of the tachometer

Remove the screw from the left hole at the back of the tachometer.

※Put the bolt store in a safe place.

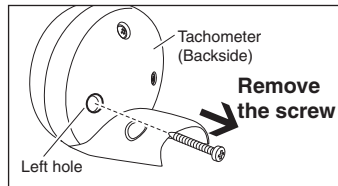

3 Decide the angle for inserting the meter

Insert the meter into the meter hood and decide the angle of insertion of the meter by aligning the hole of the stay with the screw hole at the back of the tachometer from which the screw was removed in 2 above.

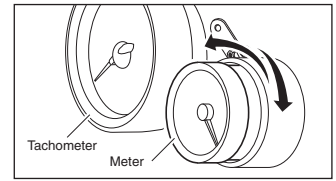

4 Fasten the meter to the meter hood

Fasten the supplied cushion tape to the meter case and fix the meter hood at the angle that was decided in 3 above.

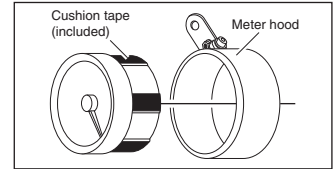

5 Fix the meter hood with the screw

1 Insert the supplied fitting spacer in the screw hole from where the screw was taken from the tachometer in 2 above.

2 Match the hole of the stay with the screw hole and use the supplied tap screw to fasten the stay.

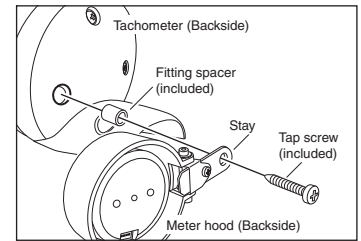

6 Connecting the 4p coupler cable

For details about wiring see p.2; connect by inserting wire into 4p coupler jack at the back of the meter.

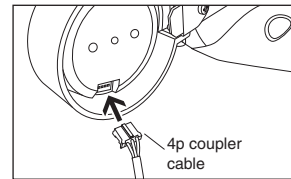

7 Return the tachometer to its original position

Return the tachometer to its original place by going in the reverse order from 1 above, and securely fasten with the two screws.

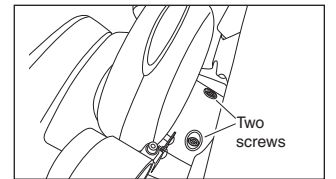

Installation B Installing to the dashboard

Fasten using the flexible stand and double-sided tape.

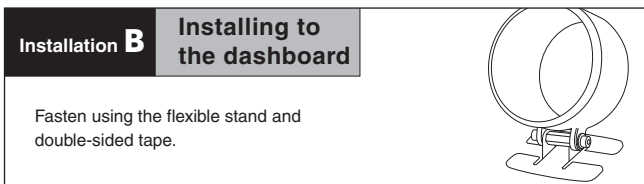

1 Remove the base of the meter hood

※Make sure not to lose any removed parts.

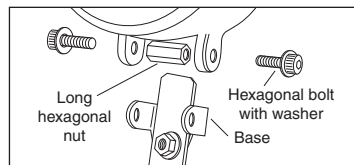

2 Affix the flexible stand

1 Insert the long hexagonal nut between the two legs of the flexible stand.

2 Firm fix by tightening hexagonal bolts.

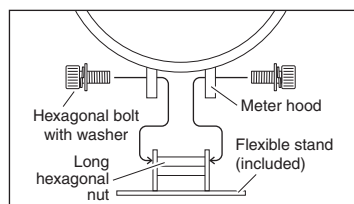

3 Fasten the meter to the meter hood

Fasten the supplied cushion tape to the meter case and fix the meter hood.

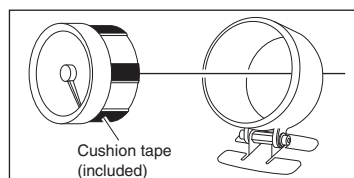

4 Installing to the car

1 Bend the stand to securely fit the place of installation.

2 Clean the surface; removing all oil or dust.

3 Fasten using the double-sided tape.

※Please be sure about where you wish to install the meter, as it is not advisable to reuse double-sided tape.

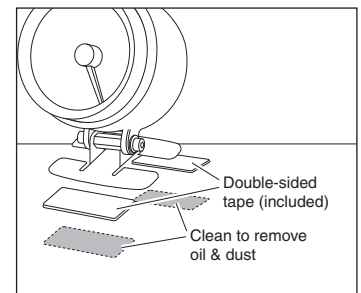

5 Adjustment of meter angle

Loosen the hexagonal bolt to decide the angle. After deciding the angle of the meter face, fasten the hexagonal bolts on both sides to secure.

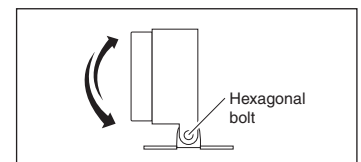

Installation C Installing into the front panel

Wrap the cushion tape around the base of the meter and forcibly insert into the 60 mm hole in the panel.

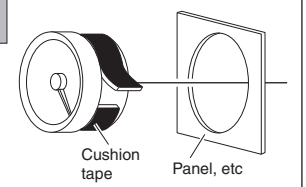

PART NAMES

1 Mode Lamp

The lamp for the current mode will light up.

2 Switch

Use to switch modes and display peak readings.

3 Needle

Shows the current values and peak readings.

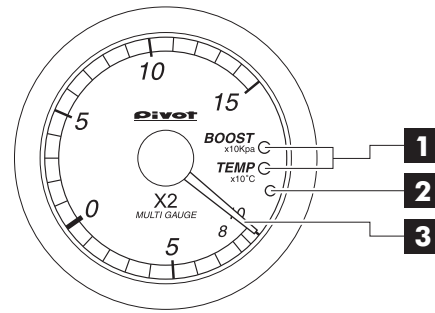

BASIC OPERATION

- 1 **Key ON** (Engine start)
- 2 **Opening Demo**
- 3 **Display Boost / Water Temperature**
- 4 **Key OFF** (Engine stop)
- 5 **Meter OFF** Due to characteristics of the gauge, even though the engine is off and the gauge is not measuring, the needle stops at the key OFF position.

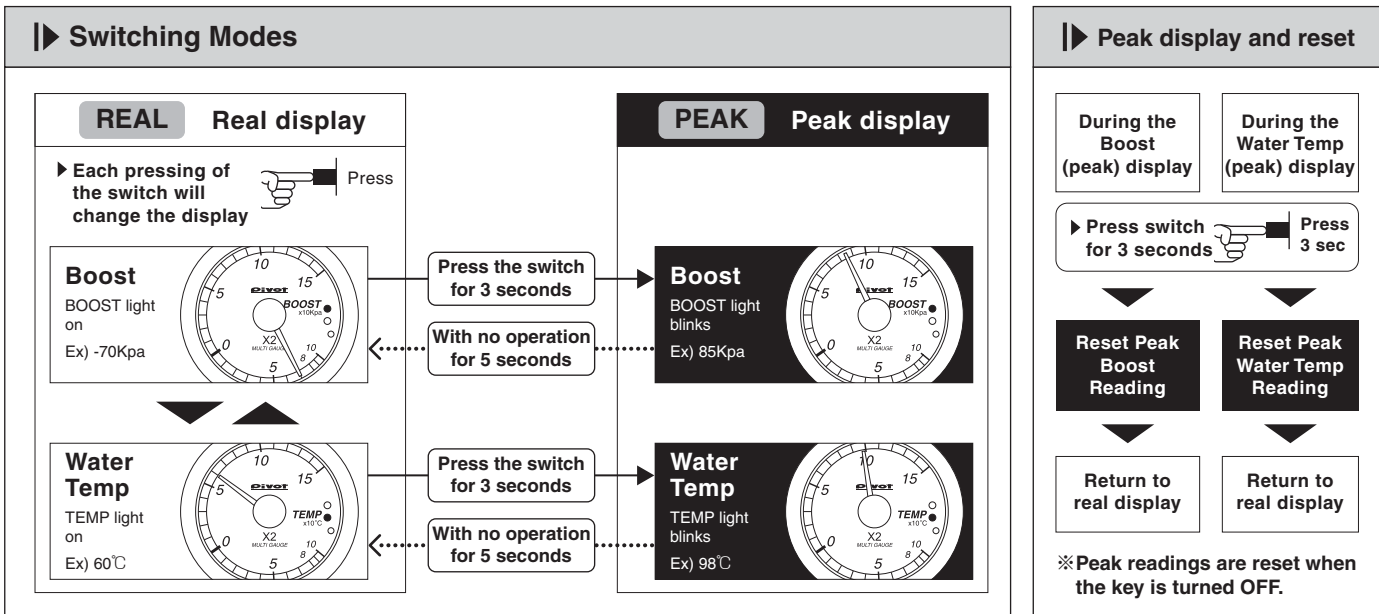

TROUBLESHOOTING

Trouble	Possible Causes	Possible Solutions
Does not work with the key ON.	Poor connection of 4p coupler, OBD2 connector or fuse.	Check the coupler connections or conditions.
	If wiring has been direct to power the red wire may have been improperly wired or there is a poor connection.	Check the red wire connections or conditions.
	The unit has been installed into an incompatible car model.	Please check the list of compatible car models.
The displayed values are different from the standard meter.	Due to the ECU information received, the displayed values on this product may differ from those of standard or other meters.	
The boost pressure display is different from the standard or other gauge.	This product's boost meter reads absolute pressure and may differ from a meter using relative pressure.	
With the key in the ON position the boost needles points to a minus reading.	The sensor for absolute pressure is subtracting for barometric pressure and hence the display shows minus. (EX: Elevation of 700 meters = minus 8Kpa)	
Upon starting up, the unit will start in the newly changed mode.	Because after changing modes, if the car's engine is turned off within three seconds, the new setting will not be stored, make sure to wait at least three seconds before turning the engine off.	
Before the opening demo starts the needle briefly moves.	This is due to a special characteristic of the meter and is not a malfunction.	