

Run Only when Absolutely Necessary:
Eco-Turbo Timer means no more unwanted idling.

e - t i m e r

Economy Auto Turbo Timer

Thank you for purchasing PIVOT e-timer. Please read these instructions carefully before installing or using this device.
Please do not lose this user's guide, as you will held liable for the cost of reissuing it.

By installing this product the user agrees that Pivot Corporation is in no way whatsoever responsible nor liable for any damage to the product or automobile or for any accident that is the result of improper installation or use of the product including any disregard by the user to the various Cautions or Warnings.

Before installing !

CAUTION

- Installation cannot be carried out on some car models; please check your car model with the Compatible Car Model List before installing.
- Please be sure to check that "e-timer" operates properly before installing it in the car or drilling holes for installation.

WARNING Improper use in disregard of this display may result in the injury or death of people.

- Be careful to turn off power switch of timer before locking the steering wheel. Using the timer with the lock on could be dangerous, if the car begins to move.
- To ensure that no accidents occur while others are using your car, be sure to turn off the power switch of the timer.
- Especially do not use if small children may be left alone in car while parked.
- Installing or using "e-timer" in places where ventilation is poor may result in an to humans due to vehicle exhaust emission poisoning or fire.
- During installation be sure to remove the minus cable from the battery so as to prevent fire and damage resulting from the shorting of circuits, etc...
- Please be careful that the cable does not get crushed by the seat rail or car door steel plate. Trying to do these operations while the car is moving, may cause trouble and damage.
- Because, it is very dangerous if, while in use, the product falls off and interferes with braking, please securely fasten it to a stable place.
- It is very dangerous to pull tangled wires by force or allow tangled wires to interfere with driving. So, please be sure to store bundle away all wires with tape, etc...
- Operating or checking the display during driving may cause an accident; please use with the utmost consideration for safety.





CAUTION Improper use in disregard of this display may cause injury to persons, damage the product and / or other things.

- When installing this product, we recommend that if technical knowledge becomes necessary please consult a qualified mechanic.
- This product is for DC12V cars; installation cannot be carried out on cars with other voltage batteries.
- Wiring should be carried out using the attached "cut connector" or by soldering, make sure to securely insulate all wiring parts with insulation tape, and confirm that no wires are sticking out. Do not use electrotap sold on the market as they may result in improper electrical connections.
- Do not, in any manner, process, take apart, or make changes to this product.
- Do not install "e-timer" in any place subject to high temperature or any place where water may be splashed.
- Do not install "e-timer" in any place subject to high temperature or any place where water may be splashed.
- When double-sided tape is used for an installation be warned that when hot the tape temporarily losses adhesiveness so no strong pressure should be applied.
- Make sure to replace all screws and parts that were removed during installation to their original place.

INDEX

1. WARNING · CAUTION · CONTENTS
2. FEATURES · ABOUT CAR SPEED SIGNAL WIRING · PART NAMES AND BASIC WIRING · MONITOR INSTALLATION
3. SWITCH OPERATIONS / EXPLANATION OF EACH DISPLAY
4. Car Speed Pulse / Engine Displacement / Car Speed Signal Wiring Setting · TROUBLESHOOTING

CONTENTS

				
Main Unit	Double-sided Tape	Cut Connectors x2	User's Guide	Car Speed Signal Wiring Diagram List

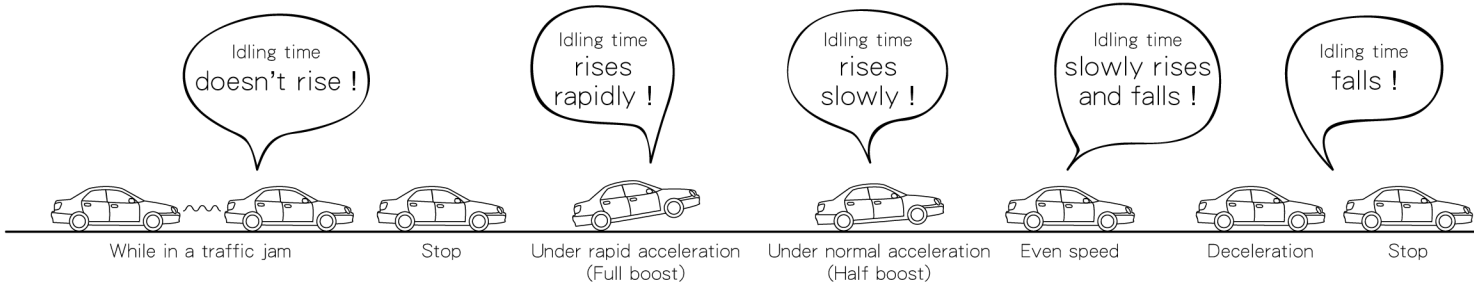

Our idea of no unnecessary idling !

Idling time doesn't rise during traffic jams or while warming up, but rises momentarily during rapid acceleration. It falls during stable driving, deceleration and when waiting at the traffic light.

By having the optimum idling time automatically set according to heat stress, there is no unnecessary idling. Also, the eco-driving support function helps to improve fuel savings and cut CO2 emissions. Moreover, the Skid Monitor warns of slippery braking conditions. These factors clearly show that our Eco Turbo Timer, which can handle safety both in the protection of our environment and protection of your engine, is indeed a new form of the turbo timer.

FEATURES

Optimum idling time saves gasoline consumption

By judging heat stress, our newly developed Real Full-Auto Mode makes it possible to run at optimal idling time and save fuel by 50~70%. (Also manual setting is possible.)

"Eco-driving" is easy to grasp and that means easy to improve fuel efficiency

The display shows the most effective acceleration and deceleration for each speed range, and if beyond this range, a blinking lamp and an alarm make it easy to follow eco-driving practices.

Safety function to prevent skidding accidents

If deceleration G's exceed the point which is assumed to be dangerous for the road condition, by blinking and giving alarm it prevent the skid accident.

Speed meter

High precision digital display shows speed up to 300km/hr in units of 1km/hr.

New Real Full Auto Theory

Because the bearings of a turbo engine are affected by heat stress from the exhaust gas temperature, it is ideal to cool them down for sometime, but to measure the exhaust temperature needs complicated installation and high cost, so the former full-auto was a slower one which did not relate to the actual heat stress, and resulted in unnecessary idling for excessively long periods of time. Moreover, because of the increase in gas prices and increased social concern about environmental problems such as the emission of CO2 gases, the question of how to reduce unnecessary idling in turbo engine cars has also become a problem to solve. Because of the relationship between heat stress and acceleration, the Real Full Auto Mode of our e-timer calculates and sets the optimum idling time from the car speed signal. This gives you the optimum idling time and makes it possible to deal both with protecting your engine and protecting our the environment by reducing CO2 emissions.

Example of Full Auto Setting Time changes

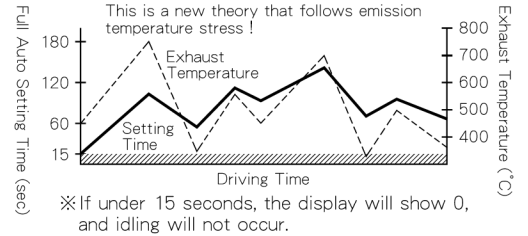

ABOUT CAR SPEED SIGNAL WIRING

Even without wiring to the car speed signal for any of the following reasons, it is possible to use some of the functions of this product.

1. When unclear about wiring to the car speed signal.
2. When wiring to the car speed signal is troublesome.

◇Function Operation Details (Functions marked X cannot be utilized.)

	Real Full-Auto	Semi Auto	Man-ual	Eco-Driving Support	Skid Monitor	Speed Meter	Model of Car
Wire to the car speed signal	●	×	●	●	●	●	For compatible car models only
Do not wire to the car speed signal	×	●	●	×	×	×	Possible for car models not listed in compatible model list

Semi-Auto Mode makes it possible to use without wiring to the car speed signal

Even without wiring to the car speed signal, it is possible to use the Manual Mode and Semi Auto Mode, which arise when in use.

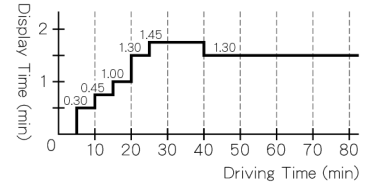

PART NAMES AND BASIC WIRING

NOTE

● For safety purposes always wire to the emergency brake. ● Be sure to check all unit operations before installing. ● For safety purposes disconnect the ⊖ terminal of the battery while installing. ● When checking the connection, be sure to reconnect the ⊖ terminal. ● If for some reason it is impossible to connect to the emergency brake make sure to earth the BROWN wire.

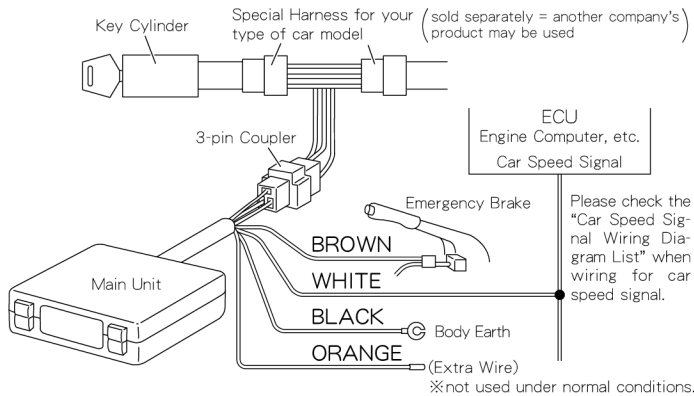

◇How to wiring ※When wiring use a special harness for your type of car model. (Another company's product may be used.)

1. Disconnect the harness of the key cylinder and between 2 cords connect the special harness.
2. Connect the 3-pin coupler cable of the special harness to the 3-pin coupler cable of the ETT main unit.
3. The BLACK wire must be connected with the screw on the car body.
4. Connect the BROWN wire to the emergency brake; make sure to securely fasten it either by soldering or by using the cut connector included in the kit.

Explanation of Wires from Main Unit

RED = Normally (Key Switch OFF) ⊕12V
 YELLOW = IG (Key Switch ON) ⊕12V
 BLUE = ACC or IG2 ⊕12V
 BLACK = Body Earth
 BROWN = Emergency Brake Switch
 ORANGE = (Extra Wire)
 WHITE = Car Speed Signal

Checking the Emergency brake Connection Spot

With the key switch ON (but not the engine) pull up to cut voltage and push down to engage ⊕12V power.

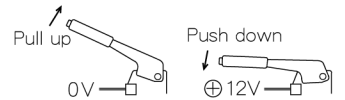

HOW TO USE THE CUT CONNECTORS

※ If soldering is possible, please do so.

Method 1	Connecting a new wire to the middle of another wire.	Method 2	Connecting two wires at their ends.
1	Peel off about 10mm of the vinyl cover at connection.	1	Peel off about 10mm of the vinyl covers at the end of the wires to be connected.
2	Twist the uncovered wires.	2	Twist the uncovered wires.
3	Close tightly with cut connector.	3	Close tightly with cut connector.

※ Use a crushing tool to press the cut connector, if you do not have such a tool, use pliers or such to fold and crush the connector together for a secure contact.

※ After covering, make sure to insulate properly with vinyl tape.

MONITOR INSTALLATION ※When affixing with the double-sided tape.

- ① Clean oil and dust from the monitor and from the area where you wish to affix it.
- ② Make sure to securely affix it with the double-sided tape provided in the kit.

⚠ Do not reuse the tape; it will lose adhesiveness.

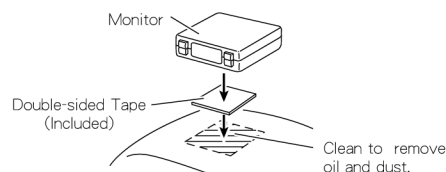

SWITCH OPERATIONS

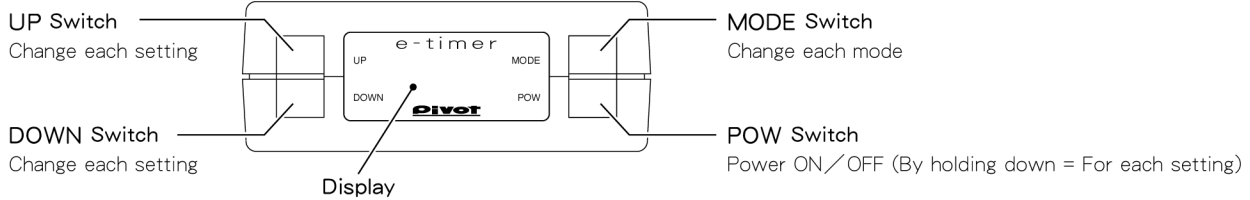

Change Main Display

- 1 Key Switch ON
- 2 Push POW Switch
- 3 Change the mode by pressing in on the MODE Switch

※Auto Setting Time for Auto Mode can be set between 15 seconds (shortest) and 3 minutes (longest) in units of one second. If set below 15 seconds, the display shows 0, and idling does not occur.

NOTE

- When idling time has been set to *Aut*, the display changes from *IDL* → *Aut* → Time.
- When idling time has been set to *Aut*, the dot at the bottom blinks during display, and turns off when set to the Manual Setting.
- If the car speed signal wiring setting is set at *no*, only *IDL* will be displayed.
- While the Timer is operating, If you release the handbrake or if you start driving in wiring to the car speed signal, *-P-* in the display will go off.

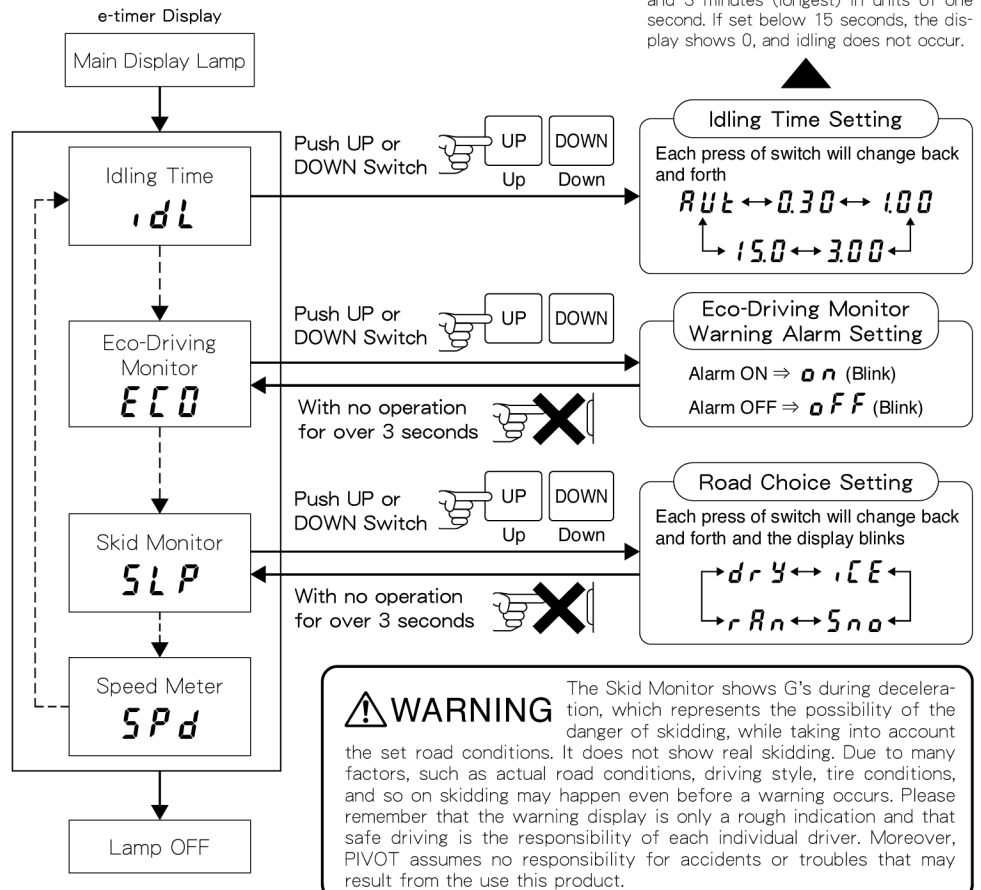

WARNING The Skid Monitor shows G's during deceleration, which represents the possibility of the danger of skidding, while taking into account the set road conditions. It does not show real skidding. Due to many factors, such as actual road conditions, driving style, tire conditions, and so on skidding may happen even before a warning occurs. Please remember that the warning display is only a rough indication and that safe driving is the responsibility of each individual driver. Moreover, PIVOT assumes no responsibility for accidents or troubles that may result from the use this product.

- 4 Push POW Switch



EXPLANATION OF EACH DISPLAY (Main Display)

Mode Name	Title	Display Example	Explanation of Example
1. Idling Time	<i>IDL</i>	<i>Aut</i>	Auto Mode (Auto Time Setting)
		<i>0.30</i>	30 seconds (Manual Setting)
2. Eco-Driving Monitor	<i>ECO</i>	<i>-no-</i>	Stop or During Even Drive ! Stable driving is the most economical.
		<i>o no</i>	During Acceleration (Eco-Driving) ! Acceleration at this stage is economical.
		<i>o no</i>	Over Acceleration Warning (Uneconomical Driving) ! Uneconomical driving. Take your foot off the accelerator and accelerate slowly.
		<i>- r r</i>	During Deceleration (Eco-Driving) ! Deceleration at this stage is economical.
		<i>- r r</i>	Over Deceleration Warning (Uneconomical Driving) ! Uneconomical driving. Try to decelerate as soon as possible, using inertia deceleration from an extended engine braking.

Mode Name	Title	Display Example	Explanation of Example
3. Skid Monitor	<i>SLP</i>	<i>ice</i>	During Deceleration
		<i>ice</i>	Light on
		<i>ice</i>	Blink + Alarm ! Be careful not to skid! It is easy to skid in this state.
Before using, set the title according to the road conditions. <i>ice</i> = On Icy Roads <i>Sno</i> = On Snowy Roads <i>rRn</i> = On Rainy Roads <i>dry</i> = On Dry Roads			
4. Speed Meter	<i>SPD</i>	<i>86</i>	86km/hr

EACH SETTING METHOD Setting the Car Speed Pulse and the Engine Displacement and the Car Speed Signal Wiring according to car model type.

Car Speed Pulse / Engine Displacement / Car Speed Signal Wiring Setting

- 1** Key Switch ON 
- 2** During Main Display
- 3** Push in POW Switch for 3 seconds 
- 4** Change the mode by pressing in on the POW Switch, after 3 seconds displays each values 

Display of each mode blinks.

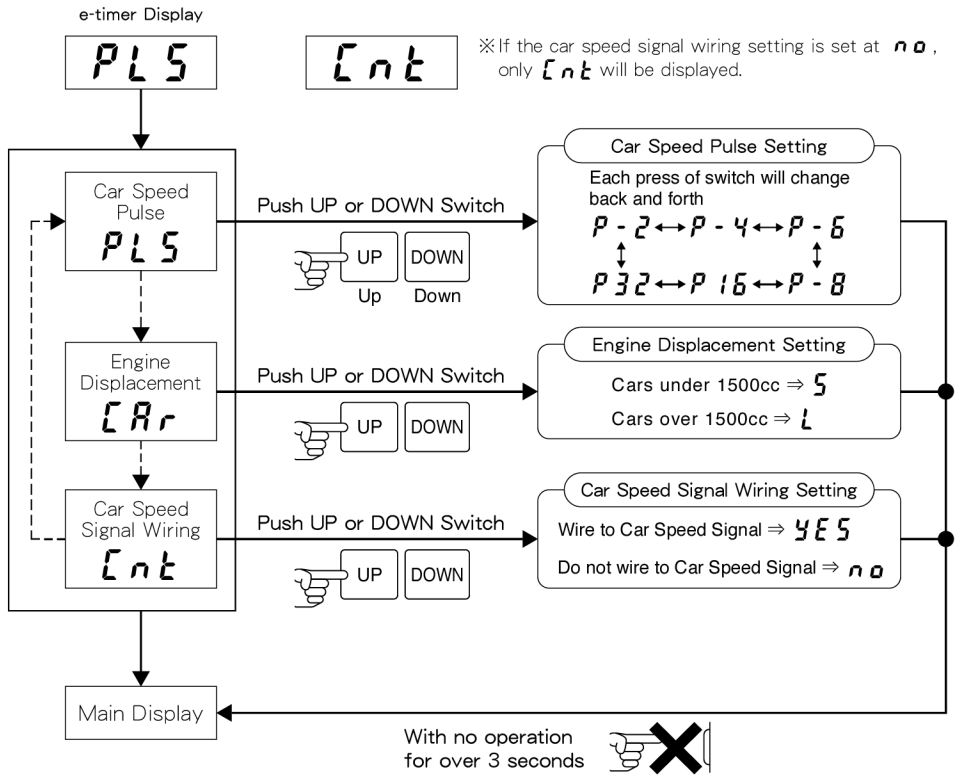

Checking normal operating

- In case of wiring to the car speed signal
 - The speed meter display is almost the same as the genuine meter.
 - Time in Auto Mode rises during rapid acceleration, and falls during deceleration.
- In case of without wiring to the car speed signal
 - In Auto Mode, five minutes after the engine has been started idling time automatically becomes 30 seconds.

- 5** With no operation for over 5 seconds 

With no operation for over 3 seconds 

Effectiveness of Real Full-Auto Mode in car models equipped with the latest system

Because Real Full-Auto Mode operates only when necessary the number of operations when compared to a standard timer is greatly lessened. Also, in some cars the problem is fixed where the standard remote control could only be used after the engine was stopped.

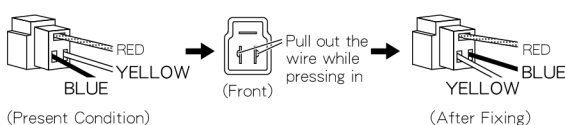
TROUBLESHOOTING FOR SOME SPECIAL CAR MODELS		※Please make the following checks before seeking repair.	
Model of Car	Trouble	Possible Causes	Possible Solutions
New SUBARU models equipped with anti-theft devices (LEGACY BL5・BP5, etc)	The security system does not work after using the Timer.	This is because the security system does not operate while the engine is running.	After stopping the engine (after idling has finished), lock the car door and activate the security system.
TOYOTA ARISTO (Later JZS161 models)	The door lock function cannot be used while using the Timer.	This is because the immobilizer and the door lock system are interconnected.	After stopping the engine (after idling has finished), lock the car door.
DAIHATSU Car	The timer operates but the engine stalls.	The polarity of the special harness is incorrect. ※1 In some special harnesses the IG1 (YELLOW) and IG2 (BLUE) positions are reversed. If this is the case, try switching the YELLOW and BLUE wires of the 3-pin coupler coming out from the Timer. ※2 Note, that doing this in other car models will render the Timer inoperative, so please return the wires to their original connection positions.	Switch the YELLOW and BLUE wires on the 3-pin coupler coming out from the Turbo Timer. 

TROUBLESHOOTING			※Please make the following checks before seeking repair.		
Trouble		Possible Causes		Possible Solutions	
With key switch ON, POW switch was pushed, but no display appears.		Contact failure of BLACK wire.		Check the BLACK wire connections or conditions.	
		An improper harness for your car model has been used.		Make sure you are using the proper harness for your car model.	
The timer operates but the engine stalls.		An improper harness for your car model has been used.		Make sure you are using the proper harness for your car model.	
		The engine inertia is weak.		To increase the torque, try increasing the engine rpm's, and operate the Turbo Timer.	
The timer display reads - P - and doesn't operate.		The handbrake has not been pulled up far enough.		Make sure to pull up the emergency brake.	
		Contact failure of BROWN wire.		Check the BROWN wire connections or conditions.	
In Real Full-Auto Mode the time on the Timer stays at 0.00 and does not move, or it quickly moves to 3.00 .		Contact failure of WHITE wire.		Check the WHITE wire connections or conditions.	
		The Car Speed Pulse Setting is wrong.		Make sure the Car Speed Pulse Setting.	
		The Engine Displacement Setting is wrong.		Make sure the Engine Displacement Setting.	

Cars with Automatic Light Controller

When using the Timer in a car equipped operating with an auto light control system, the lights may not turn off when using the Timer even after the engine has stopped. If this is the case, when using the Timer make sure to not use Auto Mode for the light control system.